

The
Complete
Joint System
Solution

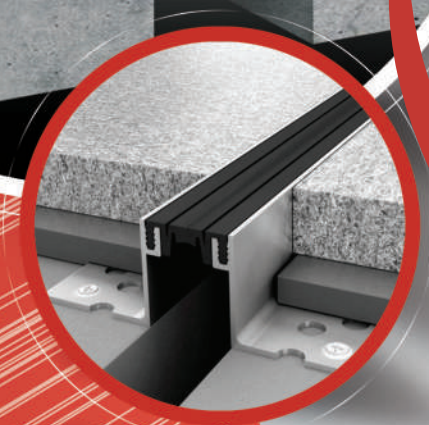
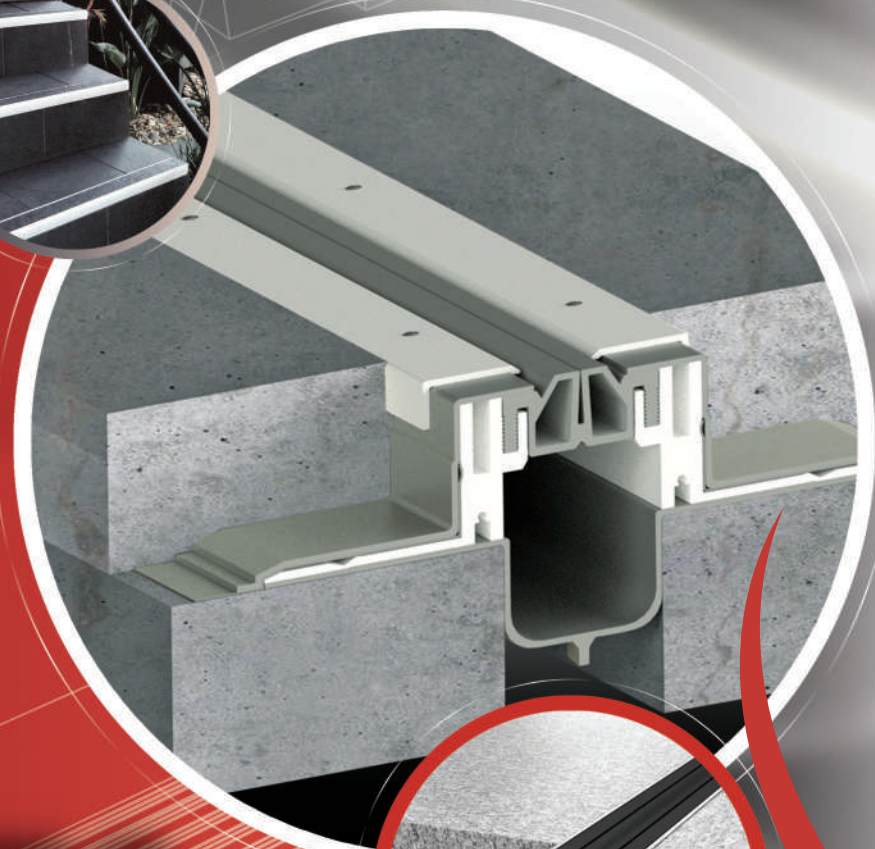

**X-Joint Building
Expansion Joint
System**

X-CALLIBUR[®]
STRUCTURAL SYSTEMS

Selection Chart

All Profiles	4-10
Floor Joint Profiles	11-30
Wall and Ceiling Profiles	31-41
Tile & Screed Profiles	42-46
Roof Profiles	47-51
ClipnStrips	52
Joint Seals	53-55
Stair Nosing	56
Floor Skirting and Alucove	57

Note to Architects and Interior Designers:

We can supply all our profiles and insert in custom colors to match the interior design.

Expansion Joints & Stair Nosing

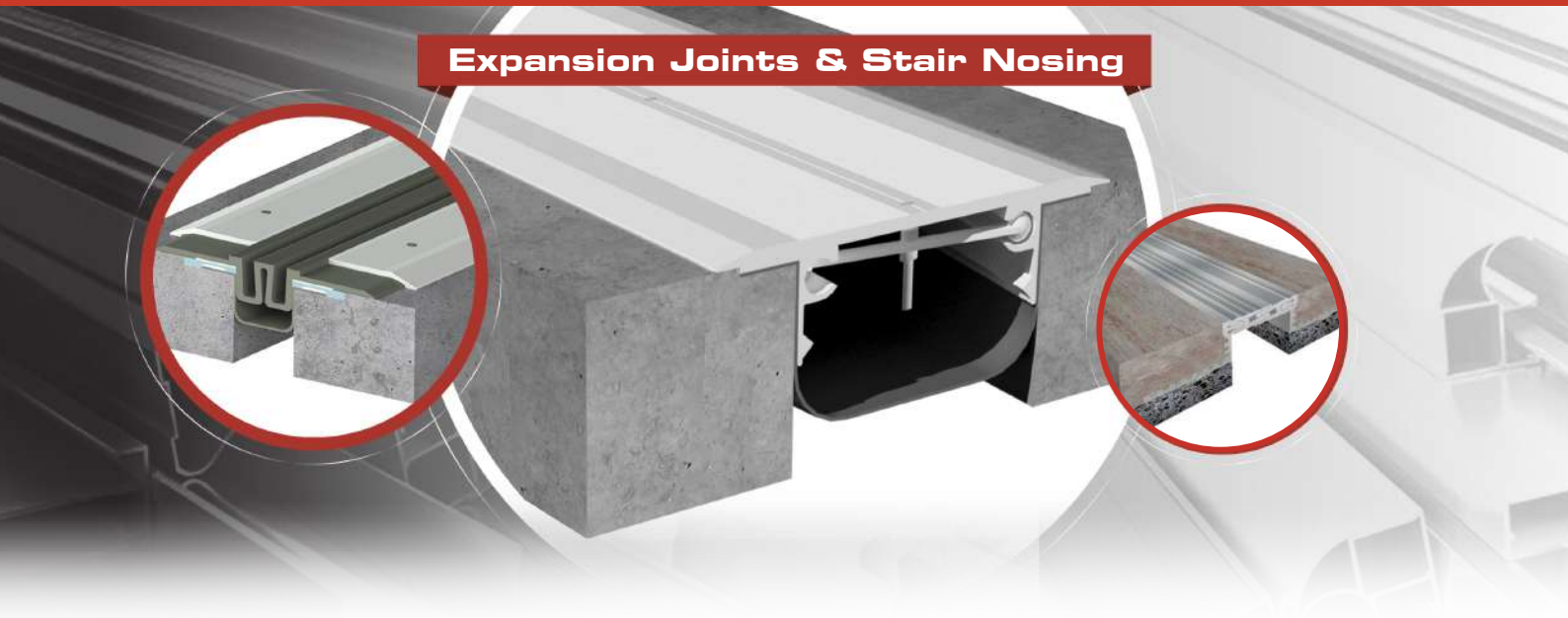

Floor Joint Profiles

Wall and Ceiling Profiles

Stair Nosing

Joint Seals

Roof Profiles

Floor Skirting

Clip Strip

Tile and Screed



X-Joint FHD-SF (Fully Waterproofed)

Heavy duty joint covers for use in car parks warehouse & ramps. Installed after completion of the final floor finish. X-Joint EPS compressible seal system are optional.

11

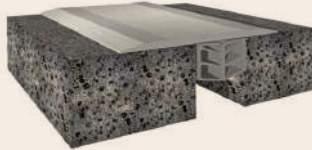

X-Joint FHD-SF (Sealed Joint)

Heavy duty joint covers for use in car parks, warehouses and ramps. Installed after completion of the final floor finish. X-Joint EPS compressible seal system are optional.

12



X-Joint FHD-SF EP

Heavy duty Extruded EPDM noise controlled joint covers for use in car parks warehouse and ramps. Installed after completion of the final floor finish X-Joint EPS compressible seal system are optional.

13

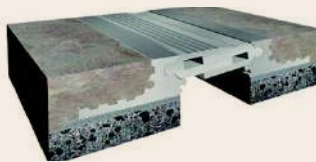

X-Joint FHD-BS

High load capacity flush fit expansion joint for use on industrial floors subject to slow moving traffic (cars, trucks, forklifts, trolleys, etc). Installed beneath the screed.

14



X-Joint FMD-SF (Fully Waterproofed)

Extruded anodized aluminum joint covers for floors in areas with heavy pedestrian slow moving light trolley traffic.

15

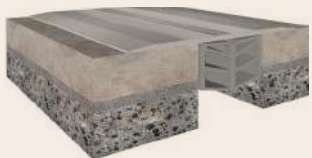

X-Joint FMD-SF (Sealed Joint)

Extruded anodized aluminum joint covers for floors in areas with heavy pedestrian traffic. X-Joint EPS compressible seal system are optional.

16



X-Joint FMD2-SF

Medium duty expansion joint for use in areas subject to heavy pedestrian and slow moving vehicular traffic. Installed after completion of the final floor finish.

17



X-Joint FMD-BS

Medium load capacity flush fit expansion joint for floors in areas subject to heavy pedestrian and slow moving cars.

18



X-Joint CPJ

Heavy duty joint covers for use in car parks warehouse & ramps. Installed after completion of the final floor finish. X-Joint EPS compressible seal system are optional.

19

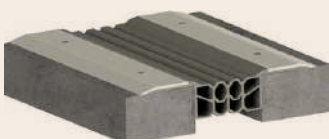

X-Joint CPJ2

Heavy duty joint covers for use in car parks warehouse & ramps. Installed after completion of the final floor finish X-Joint EPS compressible seal system are optional.

20



X-Joint FRA-BS

Extruded expansion joint for heavy pedestrian. Installed beneath the screed. Suitable for internal and external areas.

21

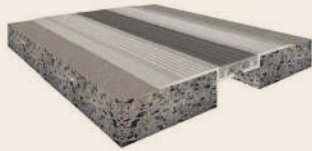

X-Joint FRA-SF

Extruded expansion joint for heavy pedestrian and slow moving vehicular traffic. Installed after completion of the final floor finish. Suitable for internal and external areas.

22



X-Joint FLP-2BS / Brass Finish

Stainless steel finish expansion joint for use with high end floor finishes. Installed beneath the screed.

23

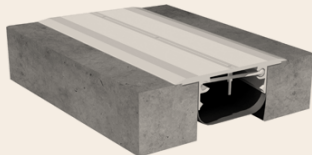

X-Joint CPS-F

High movement (seismic) expansion joint covers for use in car parks and areas subject to vehicular traffic. Installed after completion of the final floor finish.

24



X-Joint CPS-R

High movement (seismic) expansion joint covers for use in car parks and areas subject to vehicular traffic. Installed beneath the screed.

25



X-Joint CPS-S

Large movement (seismic) expansion joint for use with thin floor finishes, such as tile, marble, stone, vinyl, or carpet with minimum effect of the appearance of the floor installed beneath the screed.

26



X-Joint FFJ-BS

Large movement (seismic) expansion joint for use with thin floor finishes, tile, marble, stone, vinyl, or carpet with minimum effect of the appearance of the floor. Installed beneath the screed.

27



X-Joint FFJ-BS SE

Large movement (seismic) expansion joint for use with thin floor finishes, such as tile, vinyl, or carpet, with minimum effect of the appearance of the floor. Installed beneath the screed.

28



X-Joint 3FSP AL EHD1

High movement (seismic) flush fix expansion joint system use on open deck floors subject to slow/medium traffic. Installed beneath the screed. A fully waterproofed system.

29

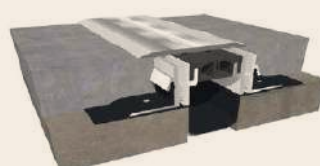

X-Joint 3FSP AL EHD2

High movement (seismic) flush fix expansion joint system used on open deck floors subject to slow/medium traffic. Installed beneath the screed. A fully waterproofed system.

30



X-Joint SWJ1

Extruded aluminum joint covers for large, seismic joints. It is used to cover exterior and interior joints on finished walls

31

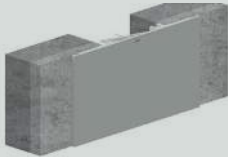

X-Joint SWJ1 SE

Extruded aluminum joint covers for large, seismic joints. It is used to cover exterior and interior joints on finished walls

32



X-Joint SWJ2

High movement capacity anodized aluminum/ PVC weather seal expansion joint for use in walls and ceilings in internal and external applications.

33



X-Joint SWJ3

Anodized aluminum expansion joint with integrated weather seal for use in wall and ceilings. Fixed directly on to the finished wall surface.

34



X-Joint SWJ4

Anodized aluminum expansion joint with visible weather seal for interior joints on walls and ceilings. Fixed directly onto the finished wall/ceiling surface.

35

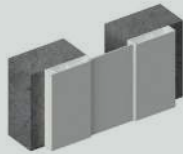

X-Joint SWJ5

Extruded aluminium seismic covers used to cover exterior and interior joints on finished walls & ceilings.

36



X-Joint CWJ1

Extruded aluminium joint covers used to cover exterior and interior joints on finished walls and ceilings, with no visible fixings.

37



X-Joint CWJ2

Anodized aluminum expansion joint with integrated weather seal for use in wall and ceilings. Installed beneath the plaster or wall board to provide a flush finish with no visible fixings.

38



X-Joint CWJ3

Extruded aluminum / PVC expansion joints for use on internal applications for walls and ceilings with gypsum board or before plastering.

39

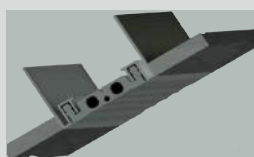

X-Joint CWJ3 FC

Extruded aluminium expansion joints with PVC/EPDM inserts on internal applications for ceilings with gypsum board/fall ceilings

40



X-Joint CPS SW

High movement seismic expansion joint cover use in walls with finished such as tile, stone marbles, provides minimum effect of the appearance of the wall. Installed beneath the finish.

41



X-Joint CJ1

Anodized aluminum EPDM, PVC, neoprene construction joint for use with tiles and stone. Installed when floor finish is being laid.

42

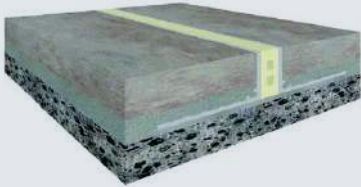

X-Joint CJ2

Anodized aluminum construction joint for use with tiles and stone. Installed beneath the screed.

43



X-Joint CJ2 SS

Anodized aluminum construction joint for use with tiles and stone. Installed beneath the screed.

44

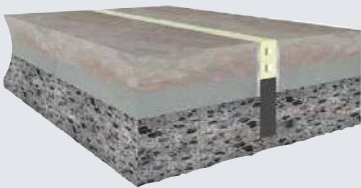

X-Joint CJ3

Stainless steel EPDM, PVC, neoprene construction joint for use with tiles and stone. Installed when floor finish is being laid.

45



X-Joint CJ4

Anodized aluminum polyurethane/polyethylene construction joint for use with tiles and stone. Accepts higher movement than neoprene. Installed when floor finish is being laid.

46

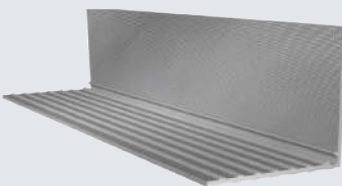

X-Joint AJS

Extruded anodized aluminium joint separators for screed and floor finishes.

46



X-Joint RJ1

Fully waterproof joint system for roof joints 10mm to 100mm wide used to cover and seal joints in accessible roofs.

47

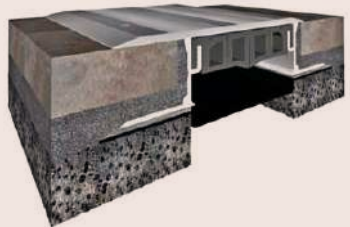

X-Joint RJ2

High movement surface fix expansion joint system use on open deck floors subject to slow/medium traffic. Installed beneath the screed and protected with suitable covers.

48

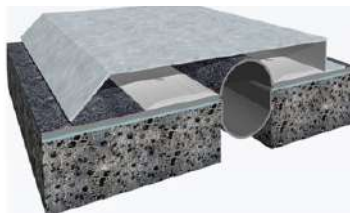

X-Joint RJ3-FL

Preformed aluminum expansion waterproof expansion joint systems that is used on roofs upstands. It is used in joints up to 300mm joint gaps.

49

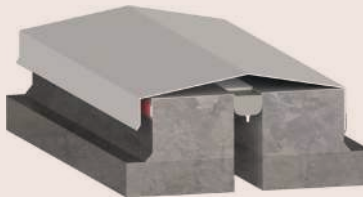

X-Joint RJ3-AL (Fully Waterproofed)

Preformed aluminum expansion waterproof expansion joint systems that is used on roofs upstands. It is used in joints up to 300mm joint gaps.

50



X-Joint RJ4

Fully waterproof joint system for roof joints 10mm to 100mm wide used to cover and seal joints in accessible roofs.

51



Floor Profiles

X-Joint ClipStrip F55F, F70F, F100F & F117F

Extruded aluminum joint covers that are suitable for use in a wide range of internal and external applications.

52



Wall Profile

X-Joint ClipStrip W70C

Extruded aluminum joint covers that are suitable for use in a wide range of internal and external applications.

52

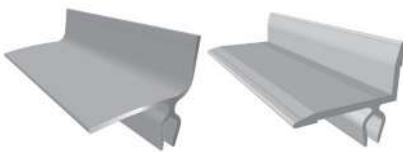

Corner Profile

X-Joint ClipStrip C50 & C100

Extruded aluminum joint covers that are suitable for use in a wide range of internal and external applications.

52



Spring Clip

X-Joint ClipStrip SS40 and SS60

For fixing X-Joint ClipStrip series.

52

Joint Seal



X-Joint EPS

Seismic waterproofing expansion joint seals for use in mechanical expansion joints.

53

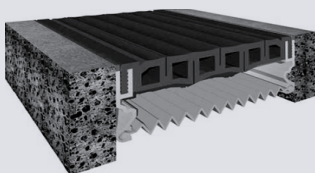

X-Joint EPS HM

High movement (seismic) waterproofing expansion joints for use in vertical and horizontal applications such as walls and slabs.

54



X-Joint EPS HD

Preformed heavy duty joint seal for use in mechanical expansion joints.

55

Extruded anodized aluminium stair nosings.

56

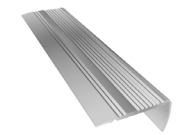

X-Joint SN 45 AA1



X-Joint SN 45 AA2



X-Joint SN 45 RS

X-Joint SN 50



X-Joint SN 80



X-Joint SN 45 Carbo™ 1



X-Joint SN 45 Carbo™ 2



X-Joint SN 50 Carbo™ 3



X-Joint SN 51 Carbo™ 4

Anodized aluminium floor skirting. Installed after the completion of floor finish.

57



X-Joint Skirting



AluCove 100

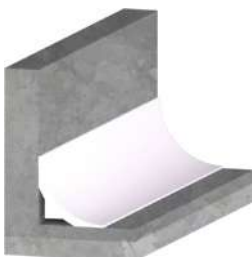

AluCove 30



AluCove W130



Description

Heavy duty joint covers for use in car parks warehouse & ramps. Installed after completion of the final floor finish. The system is fully waterproofed.

Materials:

Anodized aluminium 6063/T6. Can also be supplied in mill finish aluminium.

Waterproofing System: X-Pruf Polyliner PVC system.

Supply Lengths:

4m, custom lengths can be produced in order to minimize wastage.

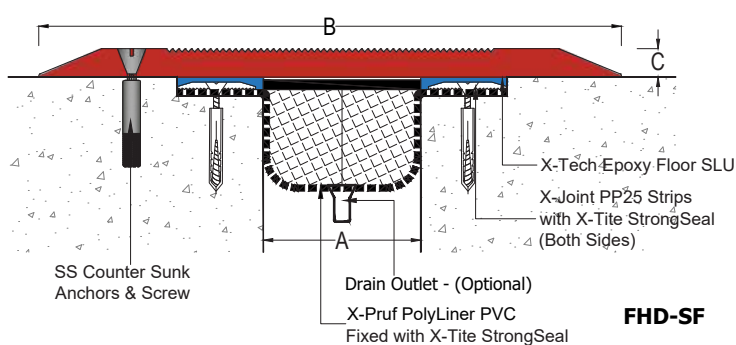

FHD-SF

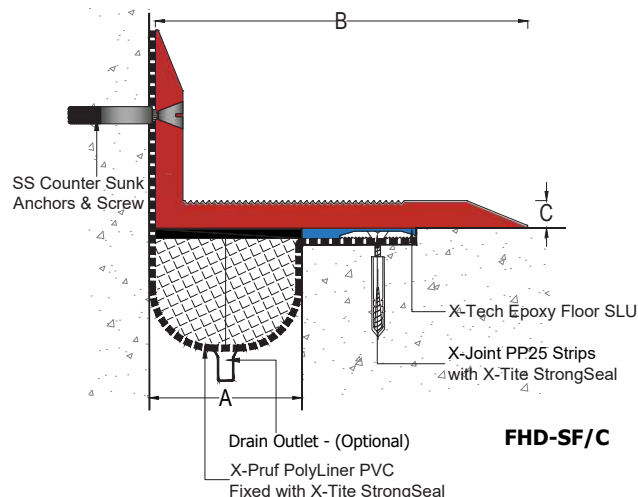

FHD-SF/C

TYPE	A	B	C
FLAT PROFILE			
FHD-SF 110/40	5 to 40	110	6
FHD-SF 155/70	41 to 65	155	8
FHD-SF 185/100	66 to 100	185	9
FHD-SF 260/150	101 to 150	260	9.5
FHD-SF 325/200	151 to 200	325	12
CORNER PROFILE			
FHD-SF/C 110/40	5 to 40	64	6
FHD-SF/C 155/70	41 to 70	122	9
FHD-SF/C 185/100	71 to 100	122	9
FHD SF/C 260 /150*	100 to 150	190	10
FHD SF/C 325 / 200*	150 to 200	255	12

*for 150 to 200mm gap the joint covers are made of custom made plate mtaching to the overall view of extruded profile supplied in mill finish

Dimension in mm



Description

Heavy duty joint covers for use in car parks, warehouses and ramps. Installed after completion of the final floor finish. EPS/Waterproofing system are optional.

Materials:

Anodised aluminium 6063/T6. Can also be supplied in mill finish aluminium.

Joint Seal: EPDM extruded gasket supplied with adhesives

Supply Lengths:

Aluminum profiles: 4m

Joint seals: 20m roll

Custom lengths can be produced in order to minimize wastage.

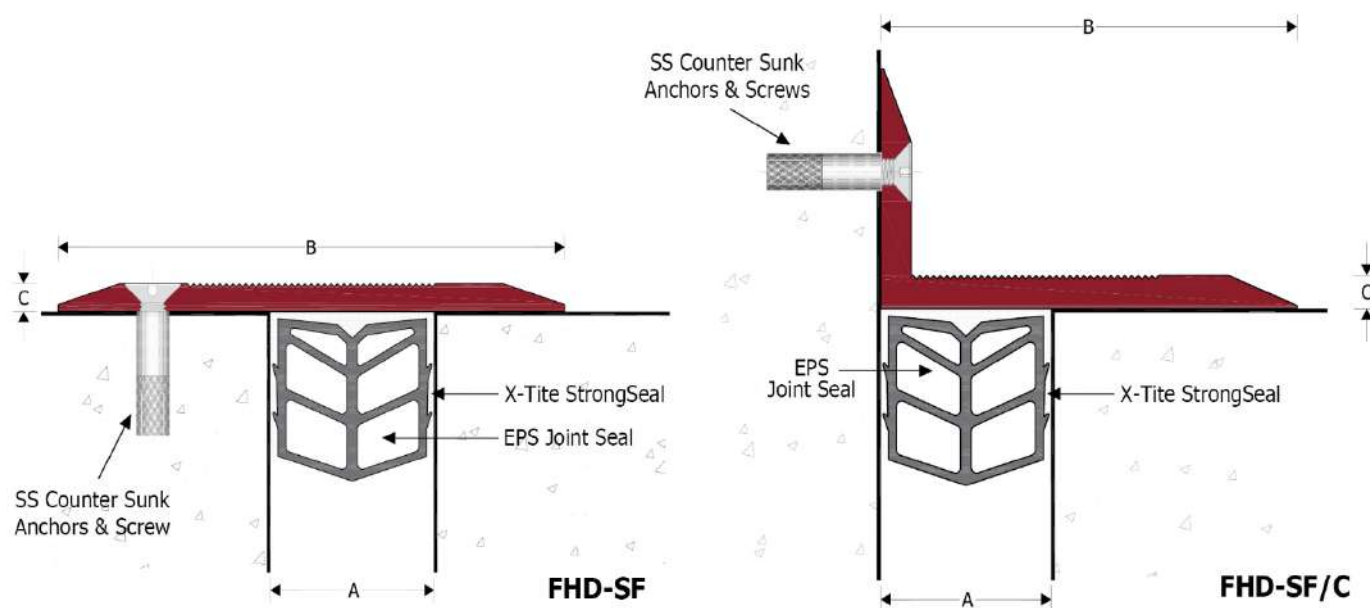

TYPE	A	B	C
FLAT PROFILE			
FHD-SF 110/40	5 to 40	110	6
FHD-SF 155/70	41 to 65	155	8
FHD-SF 185/100	66 to 100	185	9
FHD-SF 260/150	101 to 150	260	9.5
FHD-SF 325/200	151 to 200	325	12
CORNER PROFILE			
FHD-SF/C 110/40	5 to 40	64	6
FHD-SF/C 155/70	41 to 70	122	9
FHD-SF/C 185/100	71 to 100	122	9
FHD SF/C 260 /150*	100 to 150	190	10
FHD SF/C 325 / 200*	150 to 200	255	12

*for 150 to 200mm gap the joint covers are made of custom made plate mtaching to the overall view of extruded profile supplied in mill finish

Dimension in mm



Description

Heavy duty moulded EPDM noise controlled joint covers for use in car parks warehouse and ramps. Installed after completion of the final floor finish EPS/waterproofing system are optional.

Material: EPDM COVER

Load Bearing Centre Plate: MS/GI

Waterproofing System: X-Pruf Polyliner PVC System

Joint Seal: EPDM Extruded gasket supplied with adhesives

Supply Lengths: 2m

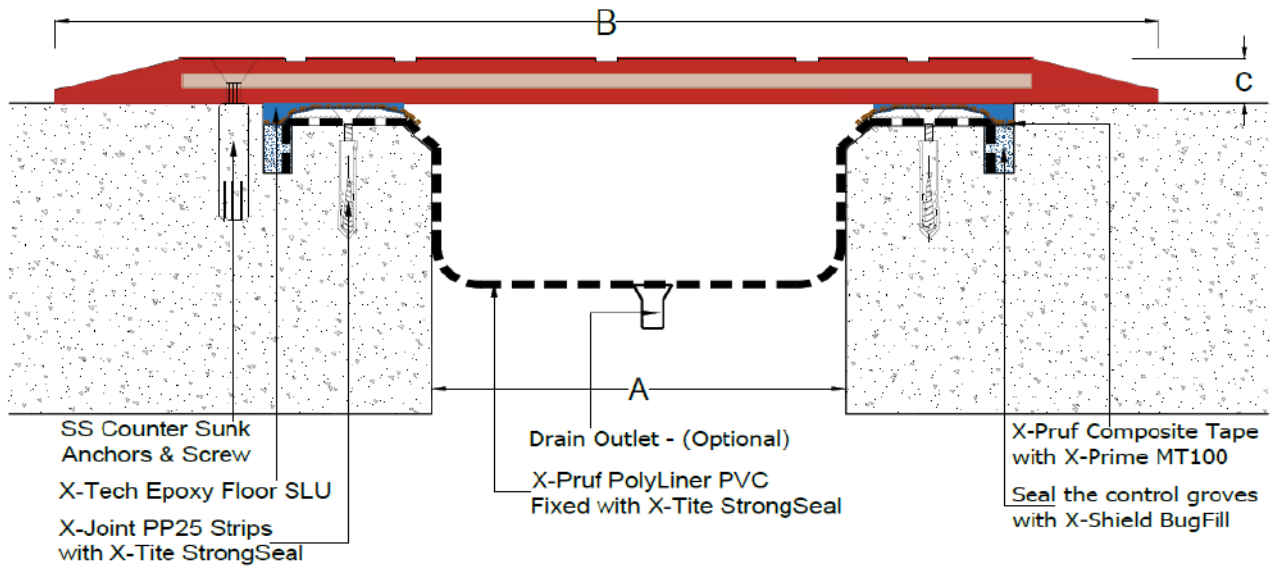

FHD-SF EP

TYPE	A	B	C
FLAT PROFILE			
FHD-SF EP 200	50 to 100	200	50'
FHD-SF EP 260	100 to 170	260	50'
FHD-SF EP 300	150 to 190	300	50'
FHD-SF EP 350	180-220	350	50'
CORNER PROFILE			
FHD-SF EP 200	50 to 100	150	50'
FHD-SF EP 260	100-170	210	50'
FHD-SF EP 300	150 to 190	250	50'
FHD SF EP 350	100 to 150	300	50'

Description

High load capacity flush fit expansion joint for use on industrial floors subject to slow moving traffic (cars, trucks, forklifts, trolleys etc). Installed beneath the screed.

Material: Anodised Aluminium 6063/T6. Can also be supplied in mill finish aluminium.

Waterproofing System: X-Pruf Polyliner PVC system

Joint Seal: EPDM extruded gasket supplied with adhesives

Supply Lengths:

4m, custom lengths can be produced against minimum order.

Load Capacity

Maximum Axle Load:

FHD-BS 50: 6 tons

FHD-BS 75: 5 tons

FHD-BS 100: 4 tons

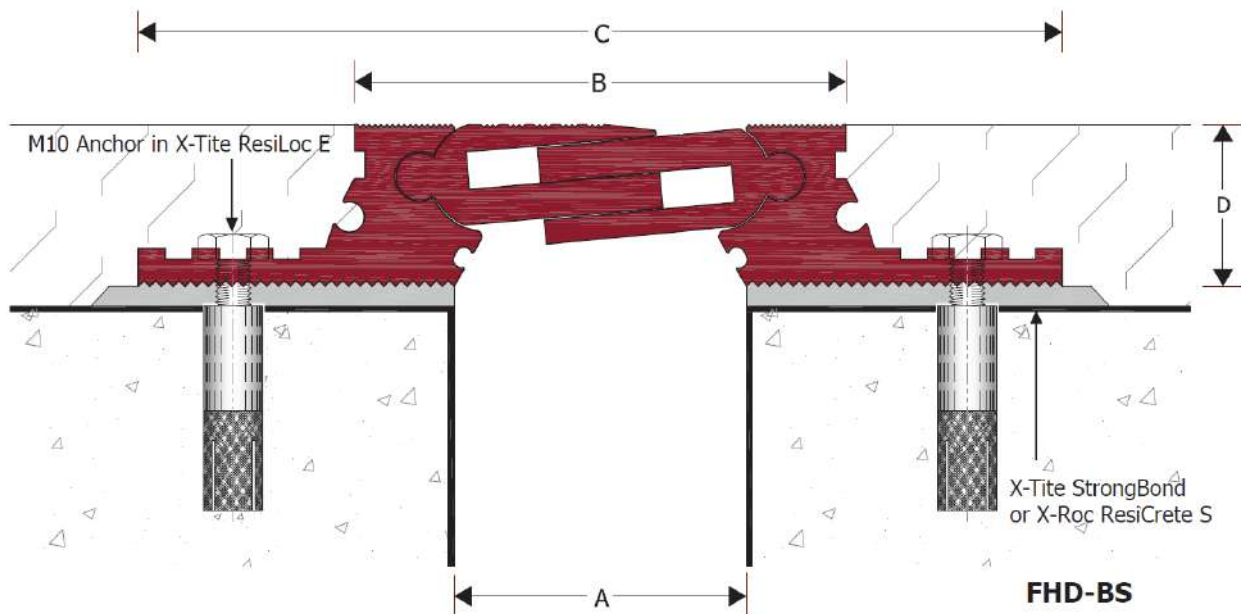

TYPE	A	B	C	D*	Total Movement
FLAT PROFILE					
FHD-BS 50	50	84	158	28	30
FHD-BS 75	75	119	195	28	40
FHD-BS 100	100	144	232	28	50

*Profile height "D" can be increased using X-Roc ResiCrete S or X-Tite Strong Bond.

Dimension in mm



Description

Extruded anodized aluminum joint covers for floors in areas with heavy pedestrian traffic.

Material: Anodised Aluminium 6063/T6. Can also be supplied in mill finish aluminium.

Waterproofing System: X-Pruf Polyliner PVC system

Supply Lengths

Aluminum Profile: 4m

Custom lengths can be produced against minimum order.

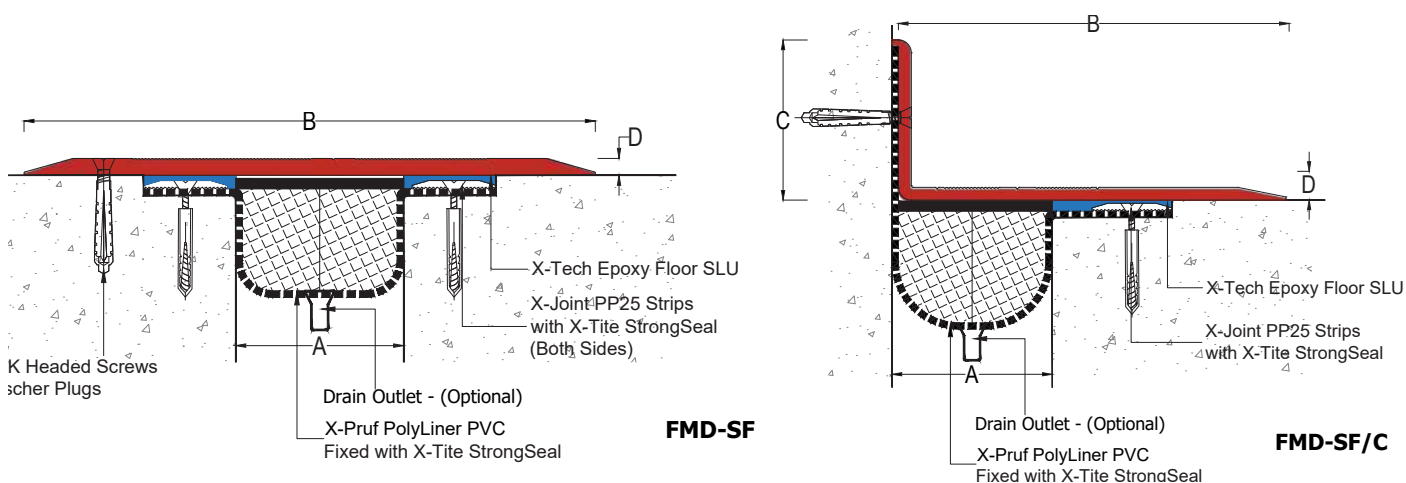

TYPE	A	B	C	D	*Total Movement
FLAT PROFILE					
FMD-SF 50	50	117	-	5	40%
FMD-SF 75	75	170	-	5	40%
FMD-SF 100	100	170	-	5	45%
FMD-SF 125	125	260	-	6	50%
FMD-SF 150	150	260	-	6	50%
CORNER PROFILE					
FMD-SF/C 50	50	64	50	4	40%
FMD-SF/C 75	75	120	50	4	40%
FMD-SF/C 100	100	120	50	4	45%
FMD-SF/C 100	125	170	50	4	50%
FMD-SF/C 125	125	170	50	4	50%
FMD-SF/C 150*	150	205	50	6	50%

*Same not as FHD SF/C corner

Dimension in mm



Description

Extruded anodized aluminum joint covers for floors in areas with heavy pedestrian traffic.

Material: Anodized aluminium 6063/T6. Can also be supplied in mill finish aluminium.

Joint Seal: EPDM extruded gasket supplied with adhesives

Supply Lengths

Aluminum profile: 4m

Joint seals: 20m roll

Custom lengths can be produced against minimum order.

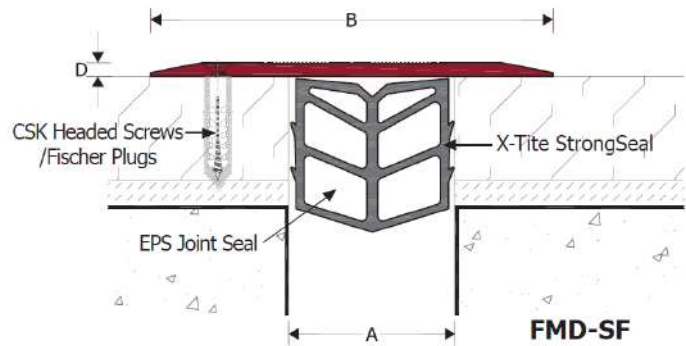
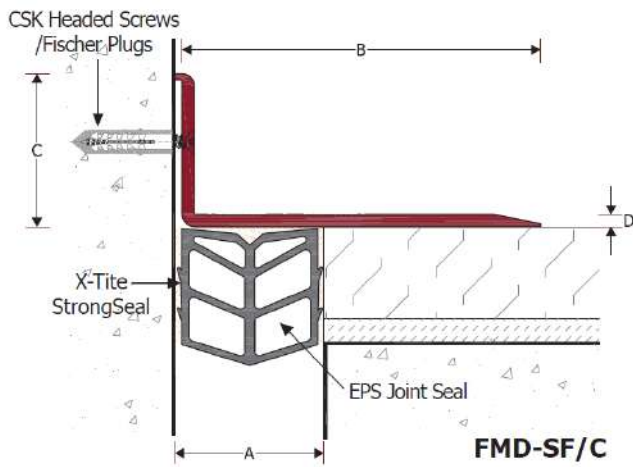

TYPE	A	B	C	D	*Total Movement
FLAT PROFILE					
FMD-SF 50	50	117	-	5	40%
FMD-SF 75	75	170	-	5	45%
FMD-SF 100	100	170	-	5	45%
FMD-SF 125	125	260	-	6	50%
FMD-SF 150	150	260	-	6	50%
CORNER PROFILE					
FMD-SF/C 50	50	64	50	4	40%
FMD-SF/C 75	75	120	50	4	40%
FMD-SF/C 100	100	120	50	4	40%
FMD-SF/C 100	125	170	50	4	45%
FMD-SF/C 125	125	170	50	4	45%
FMD-SF/C 150	150	205	50	6	45%

Dimension in mm



Description

Medium duty expansion joint for use in areas subject to heavy pedestrian and slow moving vehicular traffic. Installed after completion of the final floor finish.

Material: Anodised Aluminium 6063/T6. Can also be supplied in mill finish aluminium.

Waterproofing System: X-Pruf Polyliner PVC system

Joint Seal: EPDM extruded gasket supplied with adhesives

Supply Lengths:

4m, custom lengths can be produced against minimum order.

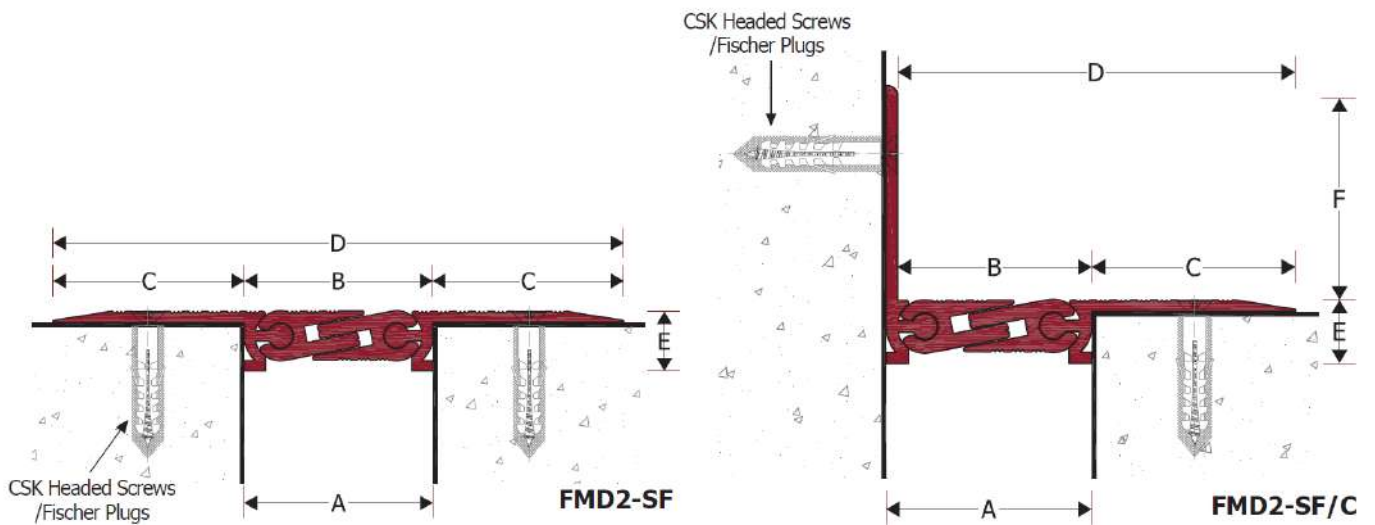

TYPE	A	B	C	D	E	F	Total Movement
FLAT PROFILE							
FMD2-SF 45	45	45	45	135	14	-	45%
FMD2-SF 60	60	60	45	150	14	-	45%
FMD2-SF 100	100	100	56	212	16	-	45%
CORNER PROFILE							
FMD-SF/C 45	45	43	45	88	14	47	45%
FMD-SF/C 60	60	58	45	103	14	47	45%
FMD-SF/C 100	100	97	56	153	16	44	45%

Dimension in mm



Description

Medium load capacity flush fit expansion joint for floors in areas subject to heavy pedestrian and slow moving cars. Installed beneath the screed.

Material: Anodized aluminium 6063/T6. Can also be supplied in mill finish aluminium.

Waterproofing System: X-Pruf Polyliner PVC system

Joint Seal: EPDM extruded gasket supplied with adhesives

Supply Lengths

4m, custom lengths can be produced against minimum order.

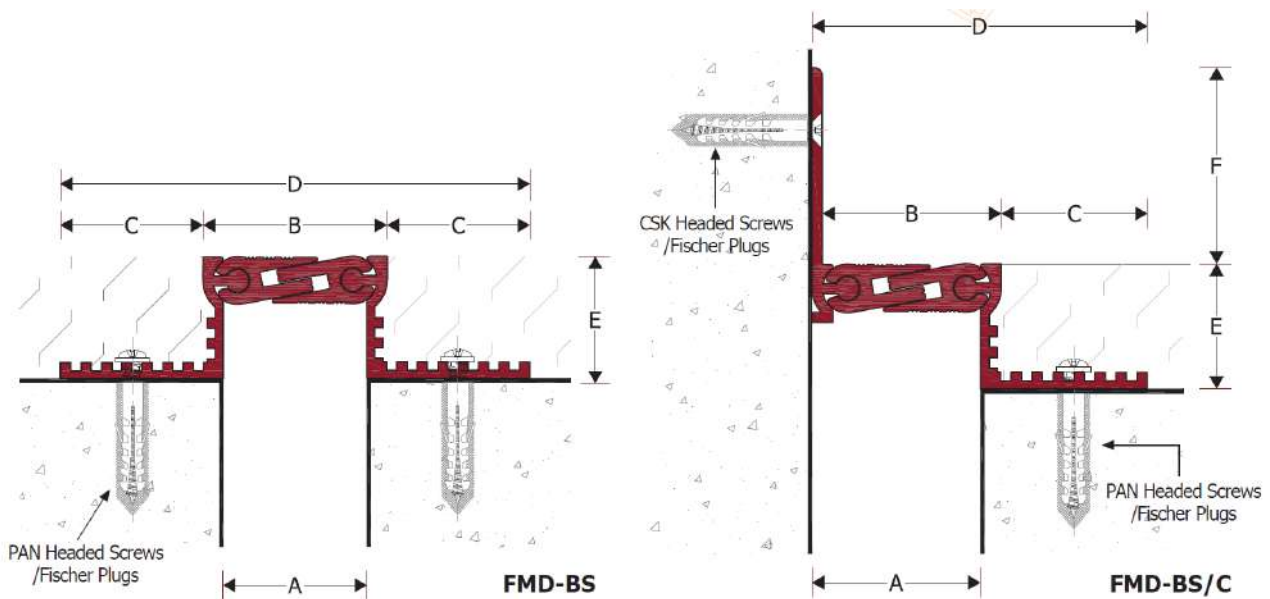

TYPE	A	B	C	D	E	F	Total Movement
FLAT PROFILE							
FMD-BS 35	35	45	35	115	30/50	-	45%
FMD-BS 50	50	60	35	130	30/50	-	45%
FMD-BS 50 H-50	50	60	35	160	50	-	45%
FMD-BS 100	100	114	48	210	50	-	50%
FMD-BS 150	150	164	48	260	50	-	50%
CORNER PROFILE							
FMD-BS/C 40	40	42	35	77	30/50	47	45%
FMD-BS/C 50	50	52	35	87	30/50	47	45%
FMD-BS/C 100	100	104	48	152	50	44	50%
FMD-BS/C 150	150	154	48	202	50	44	50%

Dimension in mm



Description

Heavy duty joint covers for use in car parks warehouse & ramps. Installed after completion of the final floor finish waterproofing system is optional.

Material: Anodized aluminium 6063/T6. Can also be supplied in mill finish aluminium.

Waterproofing System: X-Pruf Polyliner PVC system.

Joint Seal: EPDM extruded gasket supplied with adhesives

Supply Lengths

Aluminium profile: 4m

Joint seals: 10m rolls

Custom lengths can be produced against minimum order.

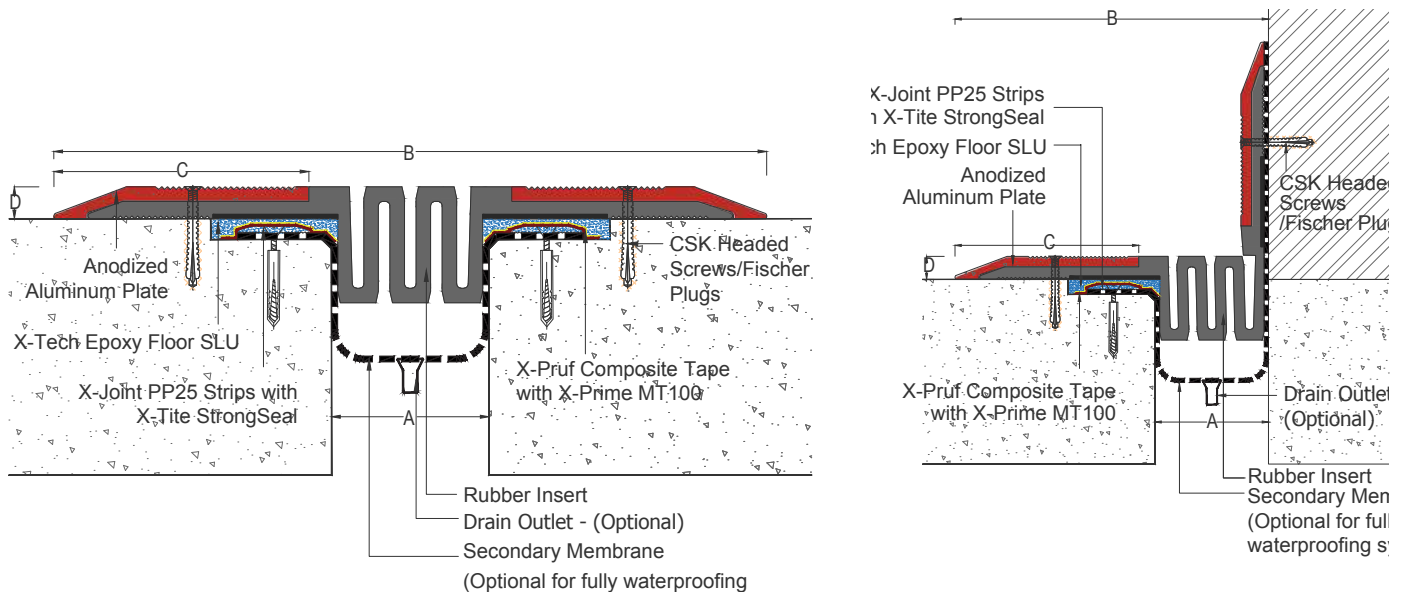

TYPE	A	B	C	Total Movement
Flat Profile				
CPJ 50	50	240	90	50
CPJ 75	75	265	90	50
CPJ 100	100	290	90	50
Corner Profile				
CPJ/C 50	50	140	90	50
CPJ/C 75	75	165	90	50
CPJ/C 100	100	190	90	50

Dimension in mm



Description

Heavy duty joint covers for use in car parks warehouse & ramps. Installed after completion of the final floor finish waterproofing system are optional.

Material: Anodised aluminium 6063/T6. Can also be supplied in mill finish aluminium.

Waterproofing System: X-Pruf Polyliner PVC system.

Joint Seal: EPDM extruded gasket supplied with adhesives

Supply Lengths

Aluminium profile: 4m

Joint seals: 10m rolls

Custom lengths can be produced against minimum order.

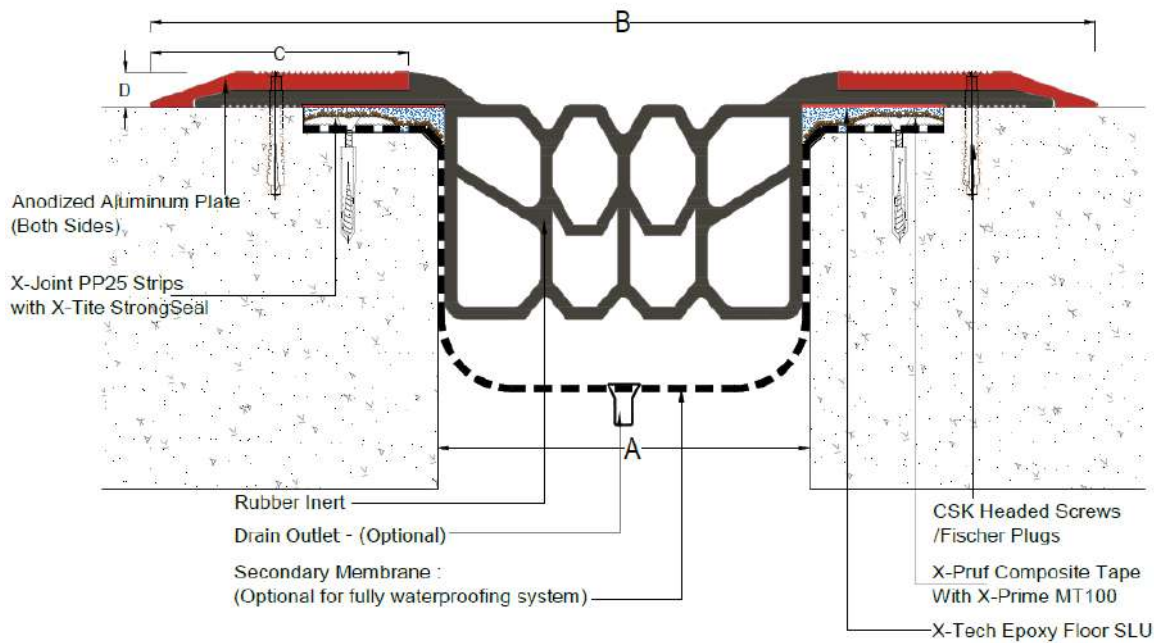

TYPE	A	B	C	Total Movement
Flat Profile				
CPJ2 50	50	240	90	50
CPJ2 75	75	265	90	50
CPJ2 100	100	290	90	50
Corner Profile				
CPJ2/C 50	50	240	90	50
CPJ2/C 75	75	265	90	50
CPJ2/C 100	100	290	90	50

Dimension in mm

Description

Extruded expansion joint for heavy pedestrian. Installed beneath the screed.

Material: Anodized aluminium 6063/T6. Can also be supplied in mill finish aluminium.

Waterproofing System: X-Pruf Polyliner PVC system

Joint Seal: EPDM Extruded Gasket Supplied with adhesives

Supply Lengths

4m, custom lengths can be produced against minimum order.

PVC Joint Seal Colour

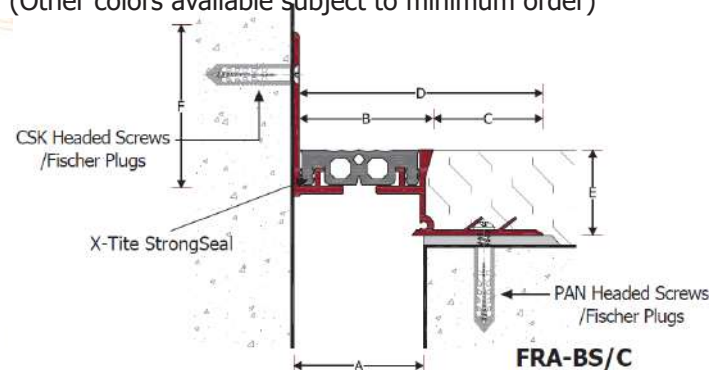
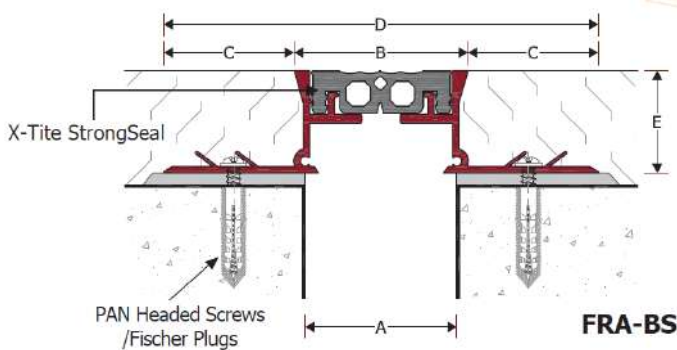

TYPE	A	B	C	D	E*	F	Total Movement
FLAT PROFILE							
FRA-BS 20	20	25	38	101	47/72	-	12
FRA-BS 30	30	35	45	125	31/97	-	20
FRA-BS 50	50	60	42	144	33	-	30
FRA-BS 75	75	85	55	194	35	-	36
FRA-BS 100	100	115	55	225	33	-	34
FRA-BS 125	125	140	54	248	33	-	64
FRA-BS 150	150	165	54	273	33	-	90
CORNER PROFILE							
FRA-BS/C 20	20	22	38	60	47/72	37	12
FRA-BS/C 30	30	32	45	77	31/97	63	20
FRA-BS/C 50	50	55	42	97	33	63	30
FRA-BS/C 75	75	80	55	135	35	68	36
FRA-BS/C 100	100	107	55	162	33	83	34
FRA-BS/C 125	125	132	54	186	33	83	64
FRA-BS/C 150	150	157	54	211	33	83	90

*Other heights are available upon request

Dimension in mm

Description

Extruded expansion joint for heavy pedestrian and slow moving vehicular traffic. Installed after completion of the final floor finish.

Material: Anodised aluminium 6063/T6. PVC / EPDM Joint Seals.

Supply Lengths:

Aluminum profile: 4m

Joint seal: 20m roll

Custom lengths can be produced against minimum

PVC Joint Seal Colour



Black



Beige



Grey

(Other colors available subject to 500m minimum order)

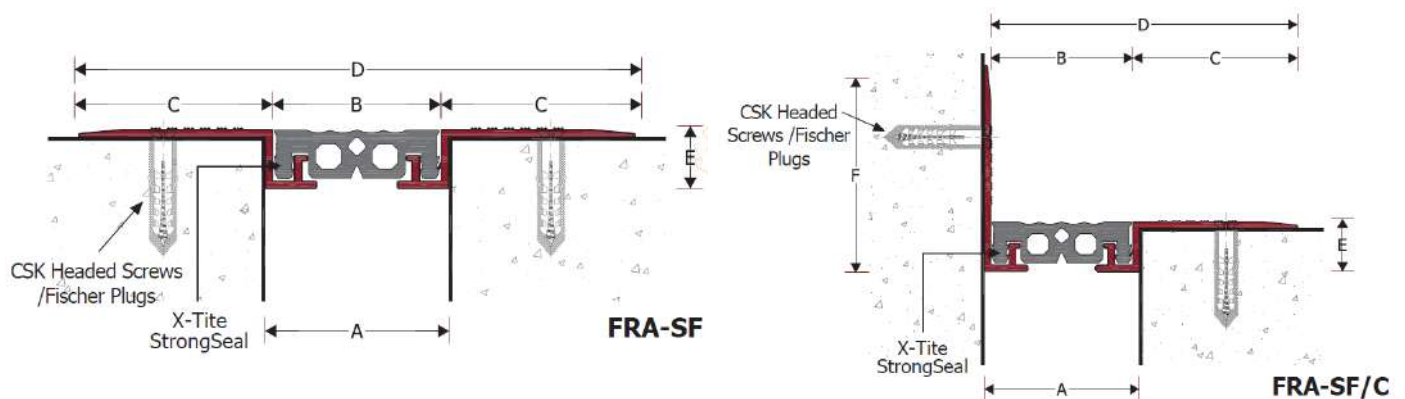

TYPE	A	B	C	D	E	F	Total Movement
FLAT PROFILE							
FRA-SF 30	30	25	43	112	16	-	20
FRA-SF 50	50	45	55	156	17	-	30
FRA-SF 75	75	69	185	185	30	-	36
FRA-SF 100	100	92	222	222	33	-	34
FRA-SF 125	125	115	265	265	33	-	64
FRA-SF 150	150	140	290	290	33	-	90
CORNER PROFILE							
FRA-SF/C 30	30	26	43	69	16	63	20
FRA-SF/C 50	50	46	55	101	17	63	30
FRA-SF/C 75	75	65	185	123	30	68	36
FRA-SF/C 100	100	96	222	161	33	83	34
FRA-SF/C 125	125	116	265	191	33	83	64
FRA-SF/C 150	150	141	290	216	33	83	90

Dimension in mm



Description

Stainless steel finish expansion joint for use with high end floor finishes. Installed beneath the screed.

Materials:

Bases: Anodized aluminium 6063/T6

Cover plates: Stainless steel (non slip) 304 or 316.

Joint Seal: PVC / EPDM

Supply Lengths

Aluminium Profile: 4m

Joint Seals: 20m roll

Stainless Steel Profile: 2.44m

Custom lengths can be produced againsts minimum order.

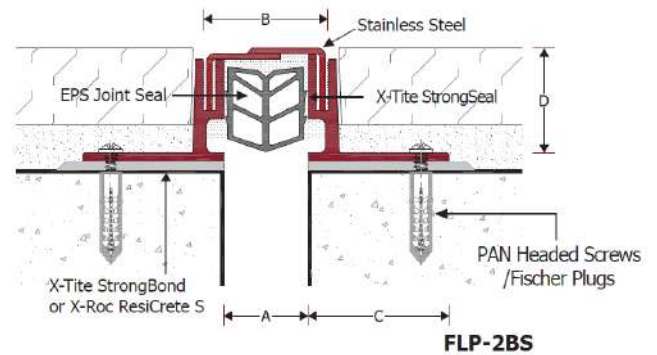
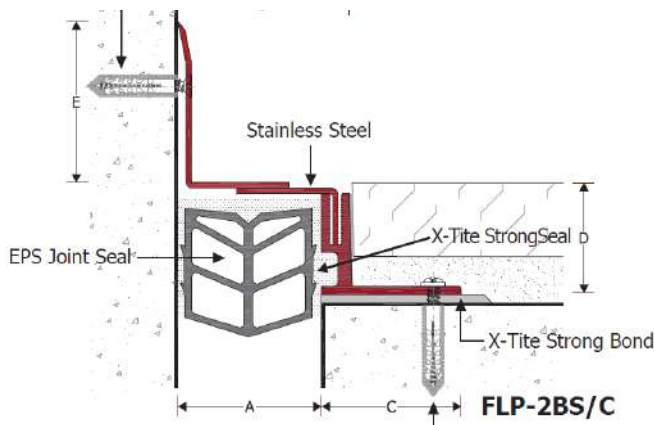

TYPE	A	B	C	D	E	Total Movement
FLAT PROFILE						
FLP-2BS 30	30	40	61	38	-	20
FLP-2BS 50	50	60	61	38	-	35
FLP-2BS 75	75	85	61	38	-	50
FLP-2BS 100	100	110	61	38	-	60
FLP-2BS 125	125	135	61	38	-	80
FLP-2BS 150	150	160	61	38	-	100
CORNER PROFILE						
FLP-2BS/C 30	30	30	61	36	60	20
FLP-2BS/C 50	50	50	61	36	60	35
FLP-2BS/C 75	75	75	61	36	60	50
FLP-2BS/C 100	100	100	61	36	60	60
FLP-2BS/C 125	125	120	61	36	60	80
FLP-2BS/C 150	150	150	61	36	60	100

Dimension in mm



Description

High movement (seismic) expansion joint covers for use in car parks and areas subject to vehicular traffic.

Materials:

Anodised aluminium 6063/T6. Can also be supplied in mill finish.

Cover Plates

Anodised aluminium 6063/t6
EPDM Covered heavy duty plate
Stainless steel: SS304/316

Waterproofing System: X-Pruf Polyliner PVC system.

Supply Lengths

Bases: 4m
Cover plate: Aluminum 4m
Stainless steel profile: 2.4m
Custom lengths can be produced againsts minimum order.

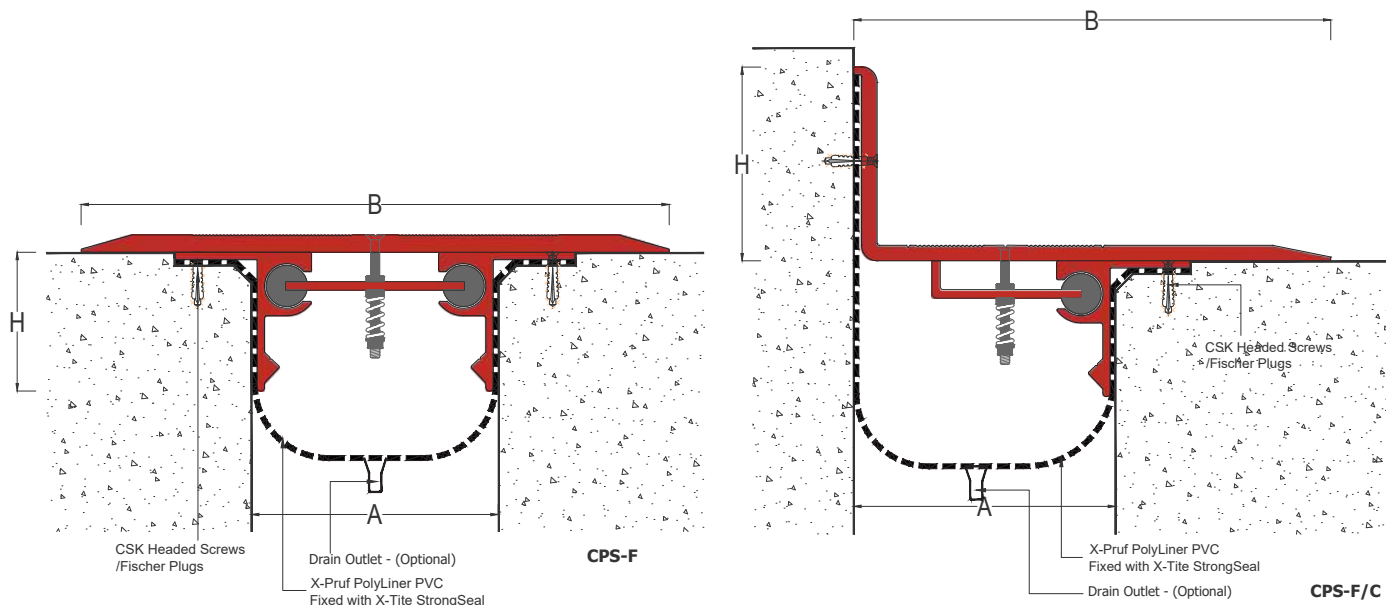

TYPE	A	B	H	Plate Thickness	Total Movement
------	---	---	---	-----------------	----------------

FLAT PROFILE

CPS-F 75	75	75	56	3	±37
CPS-F 100	100	190	56	3	±50
CPS-F 125	125	225	56	4	±62
CPS-F 150	150	250	56	4	±75
CPS-F 200	200	300	56	6	±100
CPS-F 250	250	375	56	6	±125
CPS-F 300	300	450	56	9	±150
CPS-F 350	350	525	56	9	±175
CPS-F 400	400	600	56	12	±200
CPS-F 450	450	675	56	12	±225

TYPE	A	B	H	Plate Thickness	Total Movement
------	---	---	---	-----------------	----------------

CORNER PROFILE

CPS-F/C 75	75	125	54	4	±18
CPS-F/C 100	100	145	54	4	±25
CPS-F/C 125	125	175	54	6	±31
CPS-F/C 150	150	211	54	6	±37
CPS-F/C 200	200	250	54	8	±50
CPS-F/C 250	250	312	54	8	±62
CPS-F/C 300	300	375	54	10	±75
CPS-F/C 350	350	437	54	10	±87
CPS-F/C 400	400	500	54	12	±100
CPS-F/C 450	450	562	54	12	±115

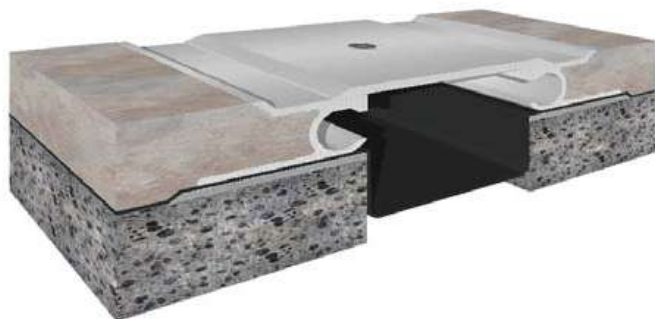

Description

High movement (seismic) expansion joint covers for use in car parks and areas subject to vehicular traffic. Installed beneath the screed.

Materials:

Base: Anodized aluminium 6063/T6
 Cover plates: Anodized aluminium 6063/T6
 Stainless steel: SS304 or 316

Waterproofing System: X-Pruf Polyliner PVC system.

Supply Lengths

Base: 4m
 Cover plates: Aluminium: 4m
 Stainless steel: 2.4m
 Custom lengths can be produced against minimum order.

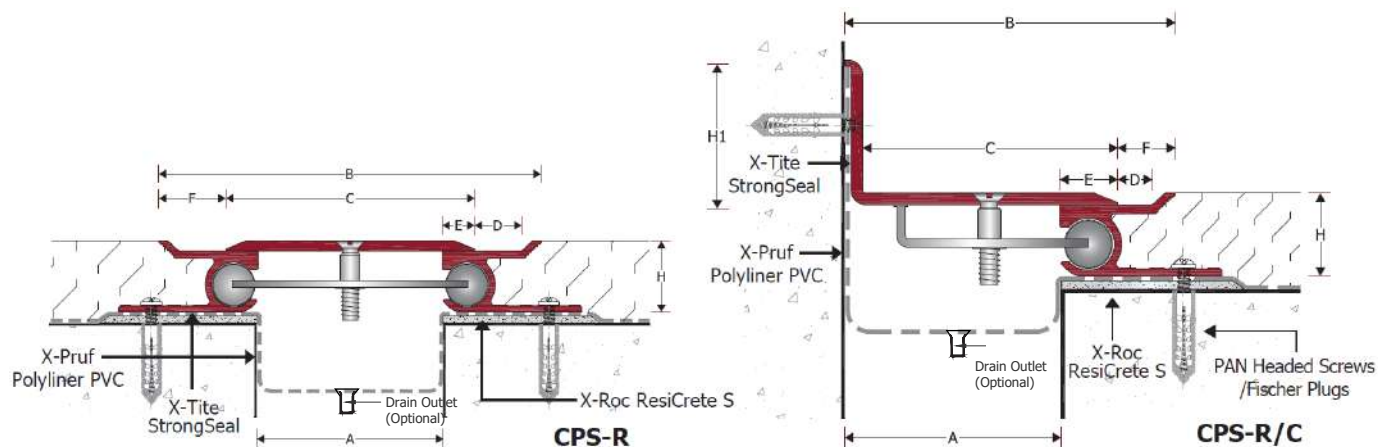

TYPE	A	B	C	D*	E*	F*	H	H1	Plate Thickness	Total Movement
Flat Profile										
CPS-R 50	50	129	78	16	15	24	29	-	5	±37
CPS-R 75	75	154	110	19	13	27	29	-	5	±50
CPS-R 100	100	179	155	6	25	14	29	-	8	±62
CPS-R 125	125	204	155	9	23	17	29	-	8	±75
CPS-R 150	150	229	200	6	25	14	29	-	6	±100
CPS-R 175	175	254	225	6	25	14	29	-	6	±175
CPS-R 200	200	279	250	6	25	27	29	-	9	±200
Corner Profile										
CPS-R/C 50	50	90	65	17	15	25	29	30	3	±32
CPS-R/C 75	75	115	88	19	11	27	29	30	3	±30
CPS-R/C 100	100	140	125	7	25	15	29	30	3	±32
CPS-R/C 125	125	165	148	9	23	17	29	30	3	±32
CPS-R/C 150	150	190	175	7	25	15	29	30	3	±32
CPS-R/C 175	175	215	200	7	25	15	29	30	3	±32
CPS-R/C 200	200	240	225	7	25	15	29	30	3	±32

Dimension in mm



Description

Large movement seismic expansion joint for use with various floor finishes, such as tile, vinyl, marble, stone, or carpet, with minimum effect of the appearance of the floor installed beneath the screed.

Materials:

Bases: Anodised aluminium 6063/T6
 Joint seals: Polyurethane sealant
 Load bearing cover plate: GI Plate (Thickness varies according to traffic load)

Waterproofing System: X-Pruf Polyliner PVC system

Supply Lengths

Bases: 4m
 Cover plates: Aluminium: 4m
 Custom lengths can be produced against minimum order.

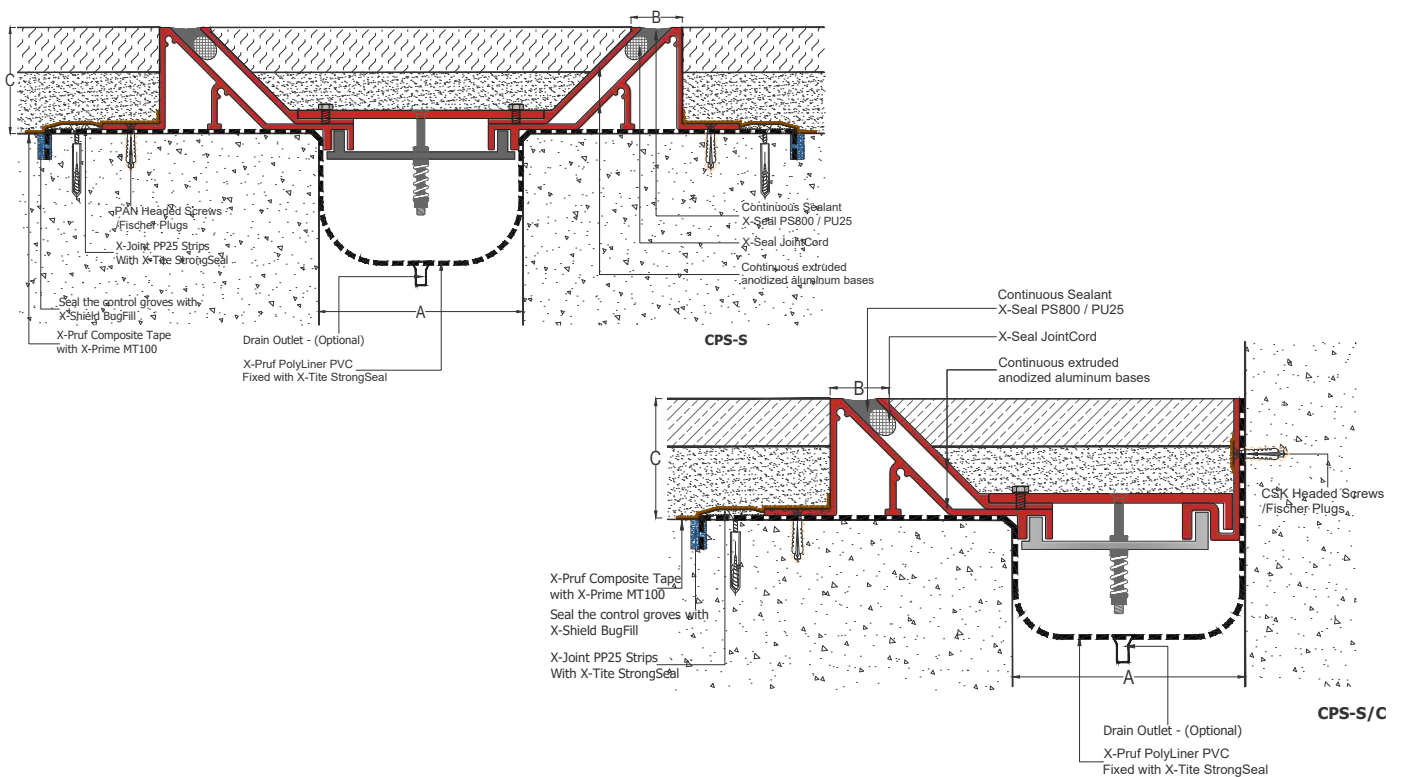

TYPE	A	B	C	Total Movement
CPS -S 50	50	15	35/50	50
CPS -S 75	75	15	35/50	50
CPS -S 100	100	15	35/50	50
CPS -S 125	125	15	35/50	50
CPS -S 150	150	15	35/50	50
CPS -S 200	200	15	35/50	50
CPS -S 250	250	15	35/50	50

Dimension in mm



Description

Large movement seismic expansion joint for use with various floor finishes, such as tile, marble, stone, vinyl, or carpet, with minimum effect of the appearance of the floor. Installed beneath the screed.

Material

Bases: Anodized aluminium 6063/T6
PVC Joint Seals / EPDM / PVC

Waterproofing System: X-Pruf Polyliner PVC system

Supply Lengths

Aluminium profile: 4m
Joint seals: 20m rolls
Custom lengths can be produced against minimum order.

PVC Joint Seal Colour



Black Beige Grey
(Other colors available subject to 500m minimum order)

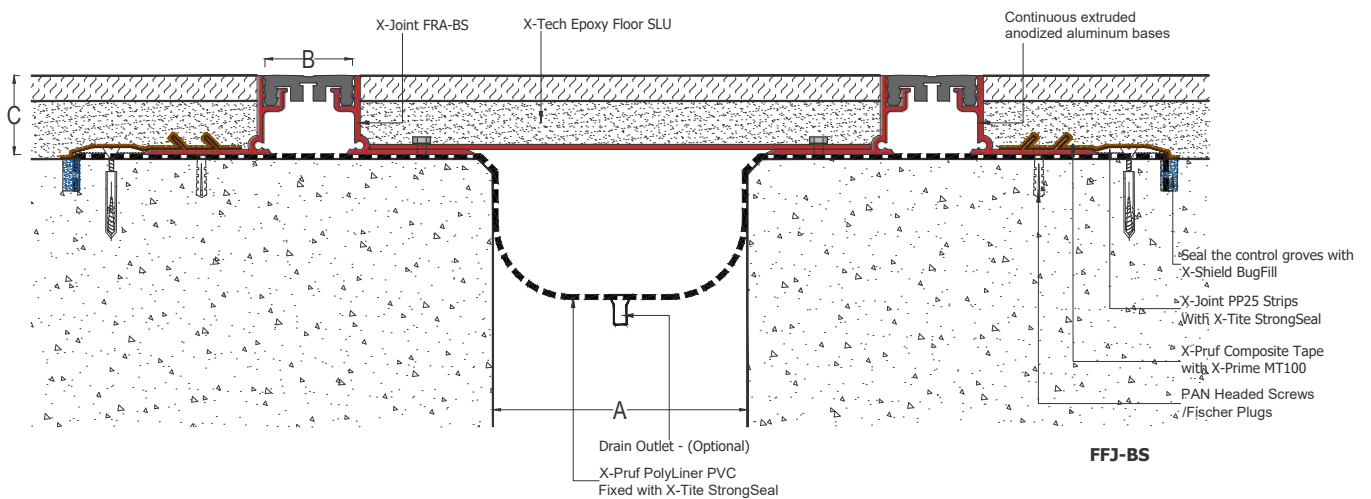

TYPE	A	B	C	Total Movement
Flat Profile				
FFJ-BS 20	20	20/30	30/47	25
FFJ-BS 30	30	20/30	31	40
FFJ-BS 50	50	20/30	33	60
FFJ-BS 75	75	30/30	35	70
FFJ-BS 100	100	50/30	33	90
FFJ-BS 150	150	75/30	35	120
FFJ-BS 200	200	75/30	33	166

Dimension in mm



Description

Large movement seismic expansion joint for use with thin floor finishes, such as tile, vinyl, or carpet, with minimum effect of the appearance of the floor. Installed beneath the screed.

Materials:

Bases: Anodised aluminium 6063/T6. PVC Joint Seal / EPDM.

Supply Lengths

Aluminium Profile: 4m

Joint Seals: 20m rolls

Custom lengths can be produced against minimum order.

PVC Joint Seal Colour



Black



Beige



Grey

(Other colors available subject to minimum order)

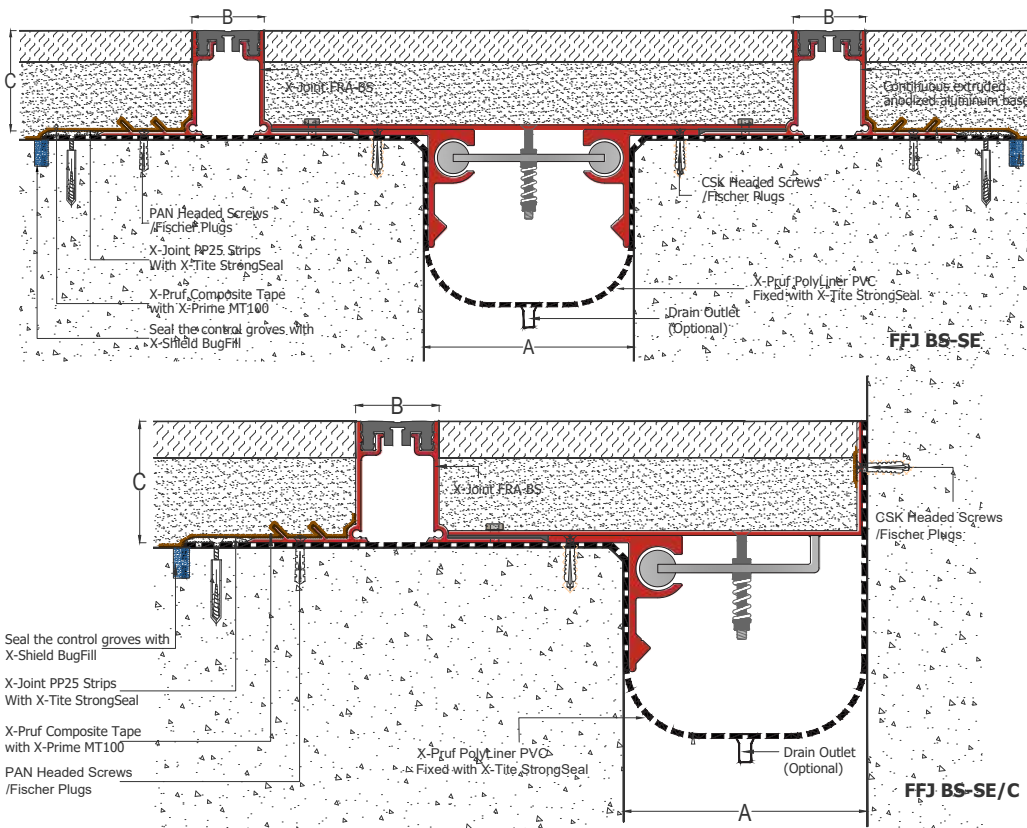

TYPE	A	B	C	Total Movement
Flat Profile				
FFJ-BS 20	20	20/30	30/47	25
FFJ-BS 30	30	20/30	31	40
FFJ-BS 50	50	20/30	33	60
FFJ-BS 75	75	30/30	35	70
FFJ-BS 100	100	50/30	33	90
FFJ-BS 150	150	75/30	35	120
FFJ-BS 200	200	75/30	33	166

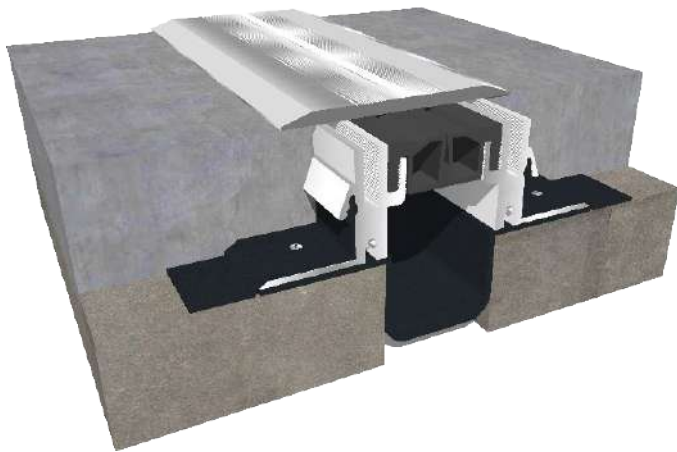

Description

High movement (seismic) flush fix expansion joint system use on open deck floors subject to heavy/medium traffic. Installed beneath the screed.

Material:

Bases: Anodised aluminium 6063/T6
 Insert: EPDM extruded gasket supplied with adhesives
 Cover plate: Stainless steel

Waterproofing System: X-Pruf Polyliner PVC system.

Supply Lengths

Base: 4m
 Insert: 20m roll
 Cover plate: 2.44m

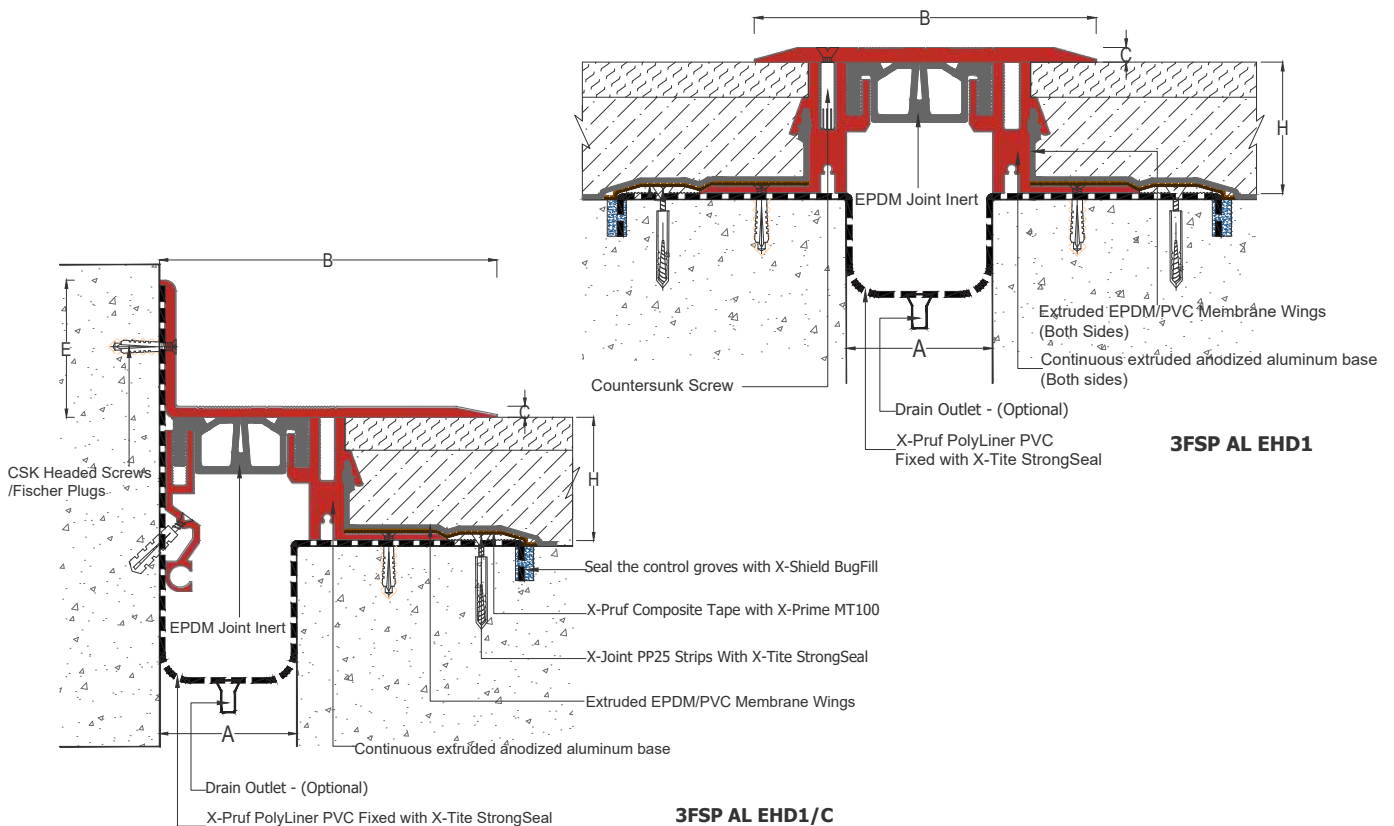

TYPE	A	B	C	H
EFSP AL EHD 50	50	110	6	45
EFSP AL EHD 75	75	155	8	45
EFSP AL EHD 100	150	185	9	45

Dimension in mm

Description

High movement (Seismic) flush fix expansion joint system use on open deck floors subject to heavy / medium traffic. Installed beneath the screed.

Material:

Bases: Anodised aluminium 6063/T6
 Insert: EPDM extruded gasket supplied with adhesives
 Cover plate: Stainless steel

Waterproofing System: X-Pruf Polyliner PVC system.

Supply Lengths

Base: 4m
 Insert: 20m roll
 Cover plate: 2.44m

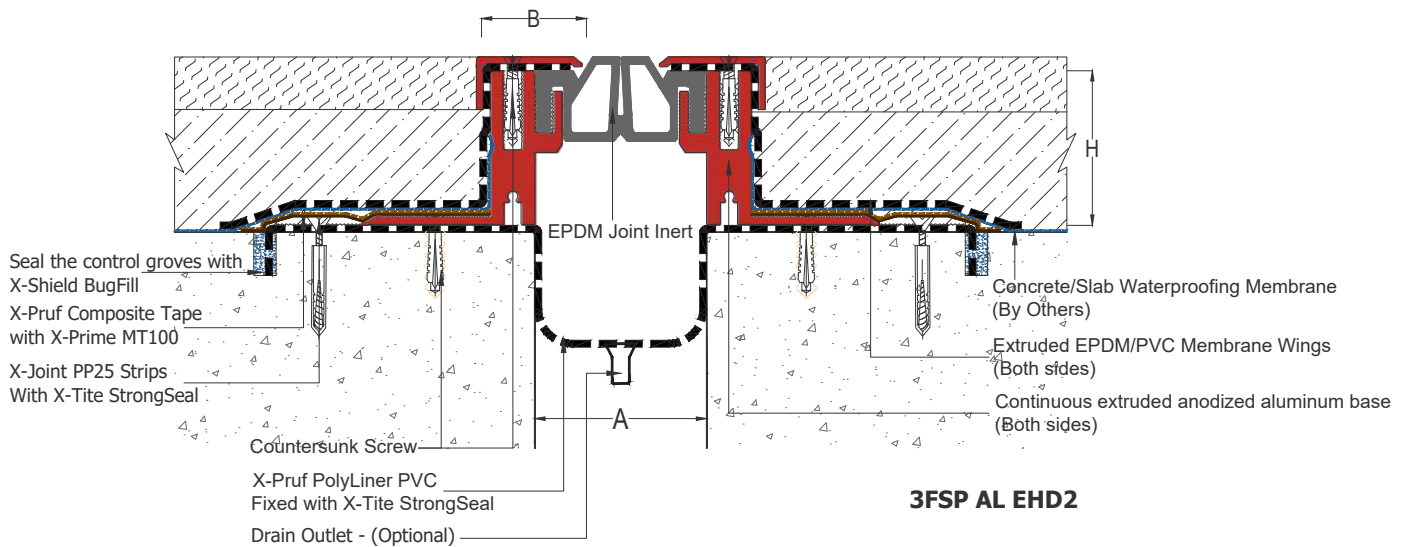
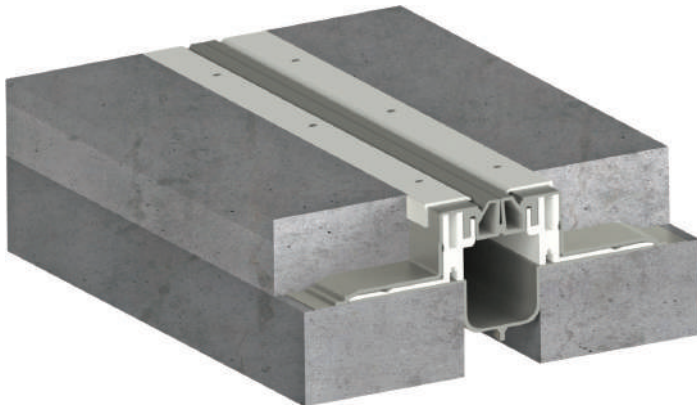

TYPE	A	B	H
EFSP AL EHD2 50	50	30	45
EFSP AL EHD2 75	75	45	45
EFSP AL EHD2 100	100	60	45

Dimension in mm



Description

Extruded aluminum joint covers used to cover exterior and interior joints on finished walls and ceilings.

Materials

Anodized aluminium 6063/T6.

Can also be supplied in mill finish and powder coated aluminum.

Supply Lengths

3m, custom lengths can be produced against minimum order.

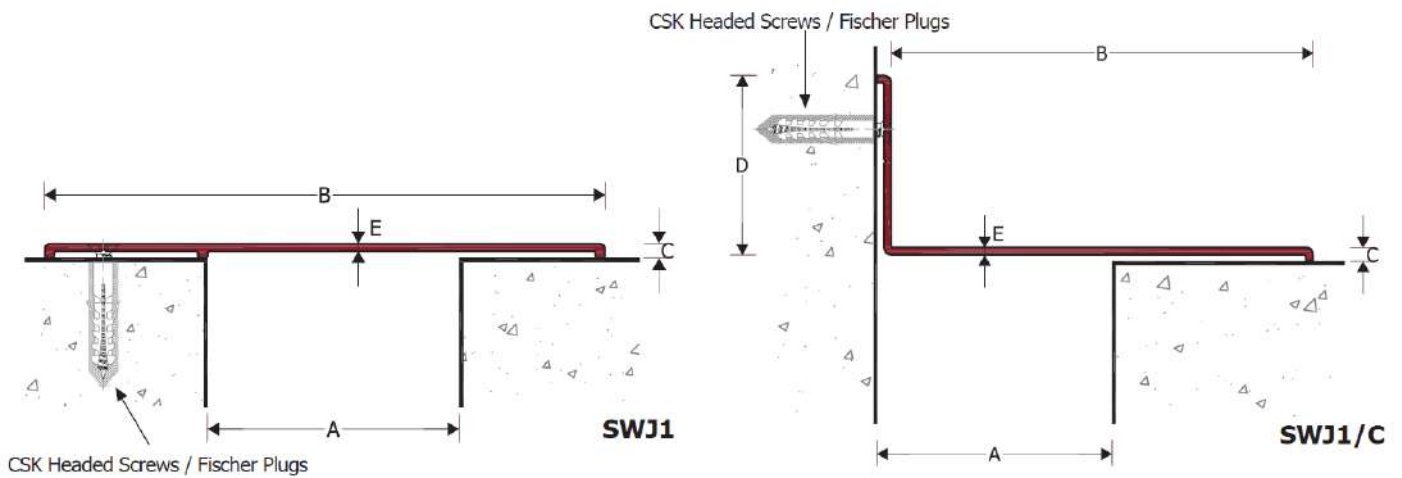

TYPE	A	B	C	D	E
Flat Profile					
SWJ1 110/40	20-40	110	3.5	3.5	1.7
SWJ1 120/70	45-60	117	3.5	3.5	1.7
SWJ1 145/110	65-80	145	5	5	1.7
SWJ1 185/140	85-100	185	6	6	2.5
SWJ1 260/180	100-150	260	6	6	3.5
SWJ1 325/200	155-200	325	6	6	3.8
Corner Profile					
SWJ1/C 70	50	67	3.5	50	1.5
SWJ1/C 120	100	117	3.8	50	2
SWJ1/C 145	120	137	6	50	3.5
SWJ1/C 185	150	167	5	50	3

*Can be used in horizontal applications subject to pedestrian loads.

Dimension in mm

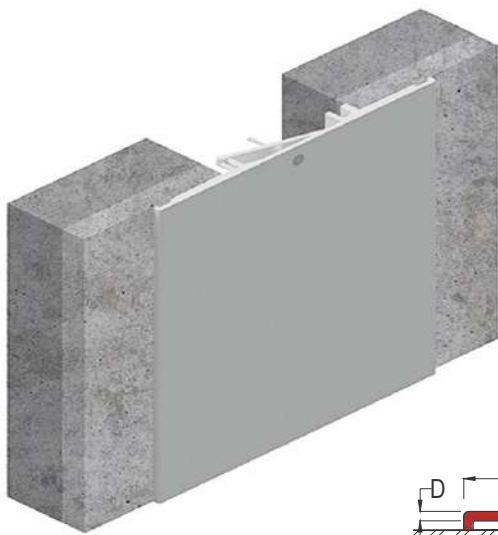

Description

Extruded aluminium seismic covers used to cover exterior and interior joints on finished walls & ceilings.

Materials

Anodised aluminium 6063/T6. Can also be supplied in mill finish and powder coated aluminium.

Supply Lengths

3m, custom lengths can be produced against minimum order.

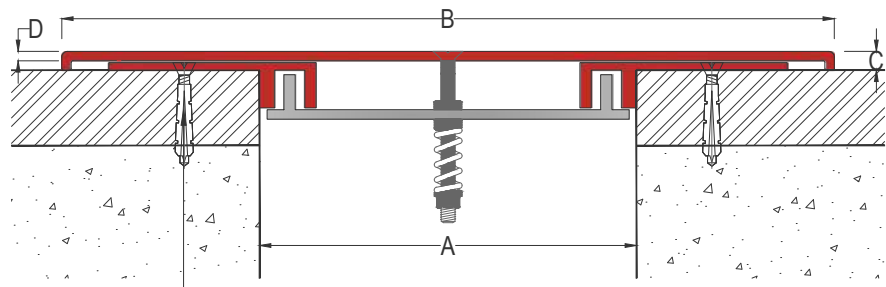

CSK Headed Screws /Fischer Plugs

SWJ1 SE

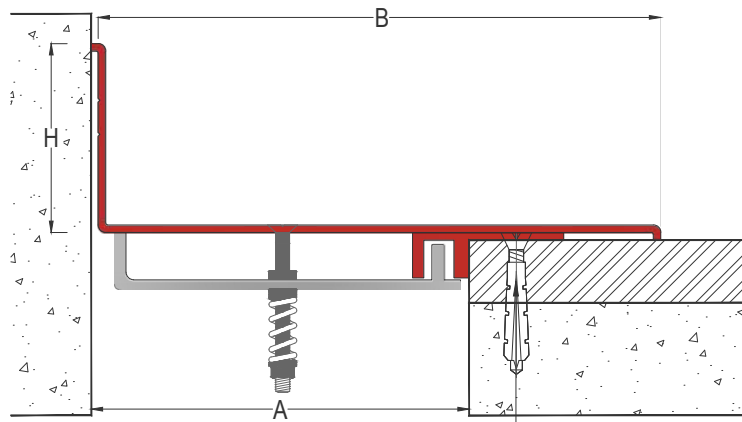

SWJ1 SE/C

CSK Headed Screws /Fischer Plugs

TYPE	A	B	C	H	Total Movement
Flat Profile					
SWJ1 SE 40	40	145	2.5	-	50
SWJ1 SE 50	50	185	3.5	-	50
SWJ1 SE 80	80	185	3.5	-	50
SWJ1 SE 100	100	200	3.5	-	50
Corner Profile					
SWJ1 SE/C 40	40	119	2		50
SWJ1 SE/C 50	50	172	3		50
SWJ1 SE/C 80	80	172	3		50
SWJ1 SE/C 100	100	172	3		50

Dimension in mm



Description

High movement capacity anodized aluminum/ PVC / EPDM weather seal expansion joint for use in walls and ceilings in internal and external applications.

Materials

Base: Anodized aluminium 6063/T6
Special PVC/EPDM joint seals resistant to sunlight

Supply Lengths

Aluminium profile: 3m
PVC/EPDM Joint seals: 50m
Custom lengths can be produced to order.

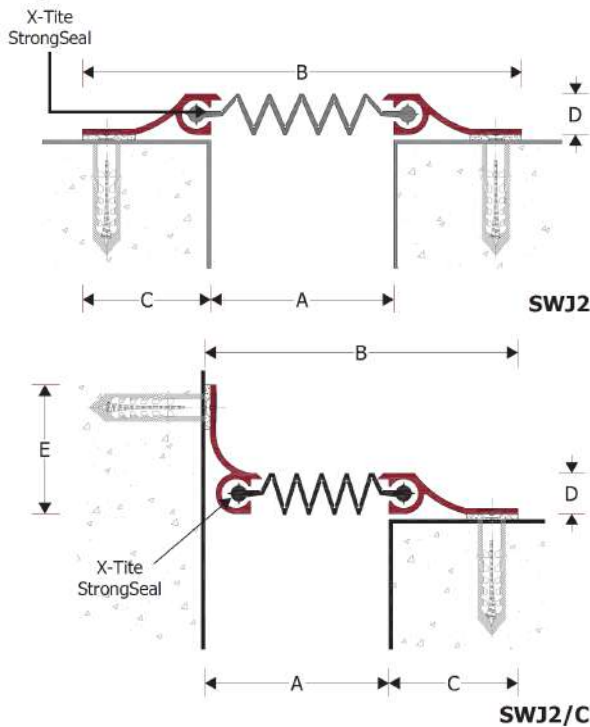

PVC Joint Seal Colour



Black



Beige



Grey

(Other colors available subject to minimum order)

TYPE	A	B	C	D	E	*Total Movement
Flat Profile						
SWJ2 25	25	95	35	11	-	55
SWJ2 50	50	120	35	11	-	100
SWJ2 75	75	145	35	11	-	150
SWJ2 100	100	170	35	11	-	200
SWJ2 125	125	195	35	11	-	250
SWJ2 150	150	220	35	11	-	300
Corner Profile						
SWJ2/C 25	25	60	35	11	35	55
SWJ2/C 50	50	85	35	11	35	100
SWJ2/C 75	75	110	35	11	35	150
SWJ2/C 100	100	135	35	11	35	200
SWJ2/C 125	125	160	35	11	35	250
SWJ2/C 150	150	185	35	11	35	300

*Movements do not take into consideration PVC elongation at break (ISO R 527)

Dimension in mm



Description

Anodised aluminum expansion joint with integrated weather seal for use in wall and ceilings. Fixed directly on to the finished wall surface.

Materials

Anodised aluminium 6063/T6
PVC/EPDM Joint Seals

Supply Lengths

Aluminium Profile: 3m
PVC/EPDM Joint Seals: 50m
Custom lengths can be produced to order.

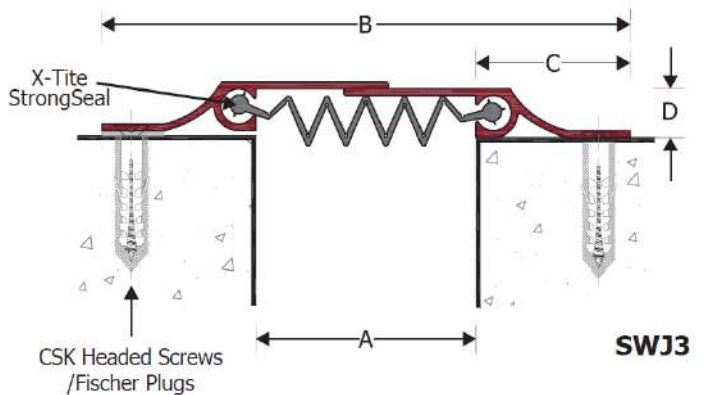
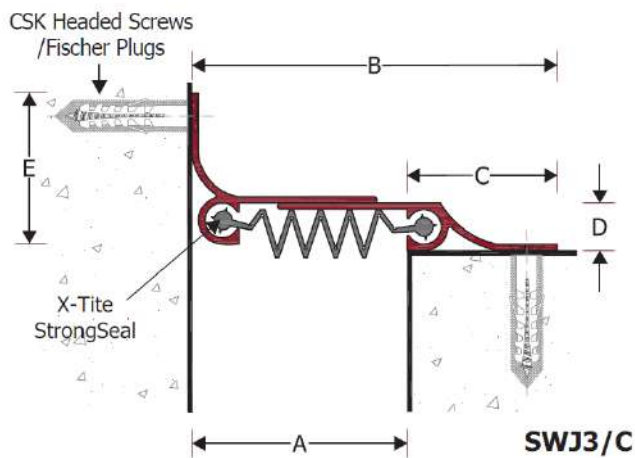

TYPE	A	B	C	D	E	*Total Movement
------	---	---	---	---	---	-----------------

Flat Profile

SWJ3 25	25	95	35	11	-	50
SWJ3 50	50	120	35	11	-	60
SWJ3 75	75	145	35	11	-	95
SWJ3 100	100	170	35	11	-	52
SWJ3 125	125	195	35	11	-	185
SWJ3 150	150	150	35	11	-	170
SWJ3 200	200	270	35	11	-	170

Corner Profile

SWJ3/C 25	25	60	35	11	35	50
SWJ3/C 50	50	85	35	11	35	60
SWJ3/C 75	75	110	35	11	35	95
SWJ3/C 100	100	135	35	11	35	152
SWJ3/C 125	125	160	35	11	35	185
SWJ3/C 150	150	185	35	11	35	170

*Movements do not take into consideration PVC elongation at break (ISO R 527)

Dimension in mm



Description

Anodized aluminum expansion joint with visible weather seal for interior joints on walls and ceilings. Fixed directly onto the finished wall/ceiling surface.

Materials

Anodized aluminium 6063/T6
PV/EPDM Joint Seals

Supply Lengths

Aluminium Profile: 4m
Joint Seals: 25m
Custom lengths can be produced to order.

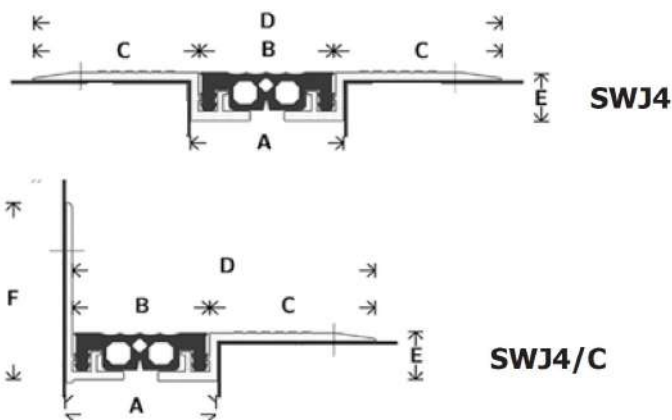

PVC Joint Seal Colour



Black



Beige



Grey

(Other colors available subject to minimum order)

TYPE	A	B	C	D	E	F	*Total Movement
Flat Profile							
SWJ4 20	20	15	38	91	16	-	12
SWJ4 30	30	26	43	112	16	-	20
SWJ4 50	50	46	55	156	17	-	30
SWJ4 75	75	69	65	185	30	-	36
SWJ4 100	100	96	75	226	33	-	34
SWJ4 125	125	115	75	265	33	-	64
SWJ4 150	150	140	35	290	33	-	90
Corner Profile							
SWJ4/C 20	20	18	38	56	16	37	12
SWJ4/C 30	30	26	43	69	16	63	20
SWJ4/C 50	50	46	55	101	17	69	30
SWJ4/C 75	75	65	58	123	30	68	36
SWJ4/C 100	100	96	65	161	33	87	34
SWJ4/C 125	125	116	55	171	17	69	64
SWJ4/C 150	150	141	55	196	17	69	90

*Movements do not take into consideration PVC elongation at break (ISO R 527)

Dimension in mm

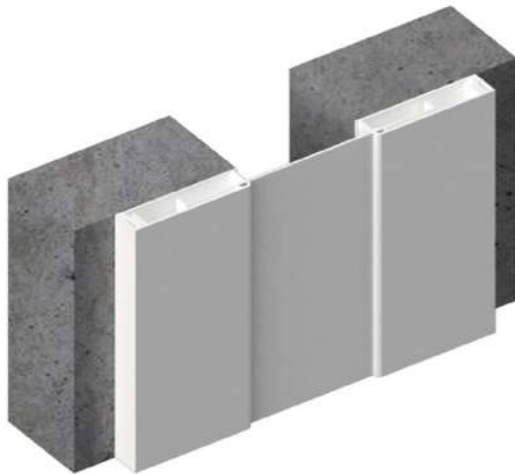

Description

Extruded aluminium seismic covers used to cover exterior and interior joints on finished walls & ceilings

Materials

Anodised aluminium 6063/T6. Can also be supplied in mill finish and powder coated aluminium.

Supply Lengths

3m, custom lengths can be produced against minimum order.

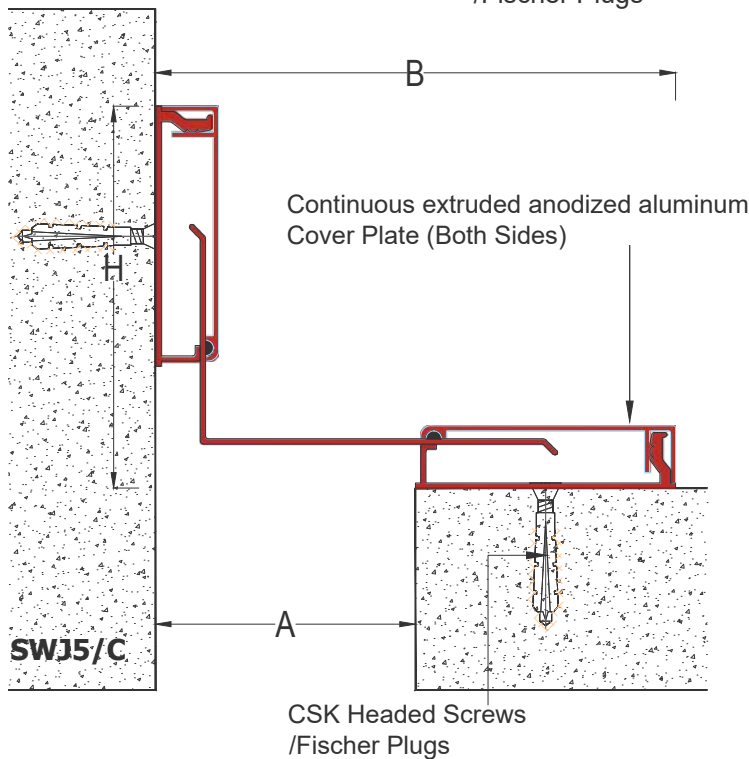
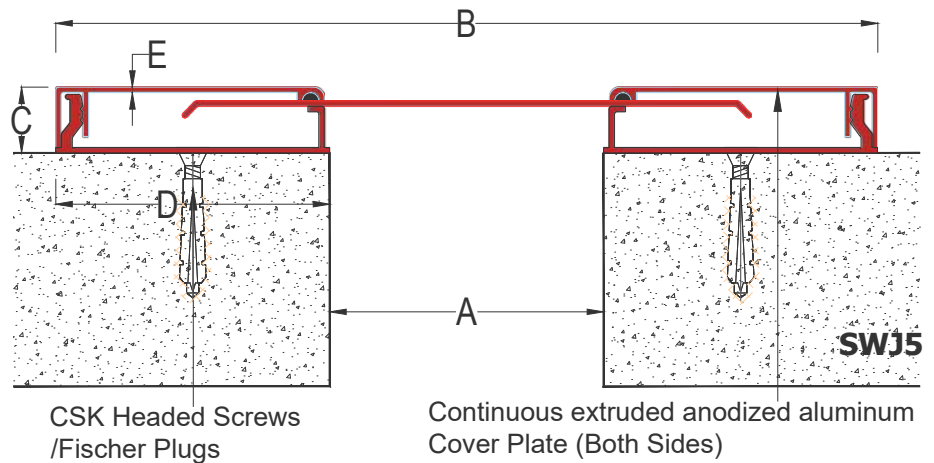

TYPE	A	B	C	Total Movement
Flat Profile				
SWJ5 50	50	150	12	50
SWJ5 100	100	200	12	50
SWJ5 150	50	250	12	50
SWJ5 200	100	300	12	50

Dimension in mm



Description

Extruded aluminium joint covers used to cover exterior and interior joints on finished walls and ceilings, with no visible fixings.

Materials

Anodized aluminium 6063/T6
Also available in mill finish / powder coated.

Supply Lengths

3m, other widths (B) available with pre-formed aluminum plates.

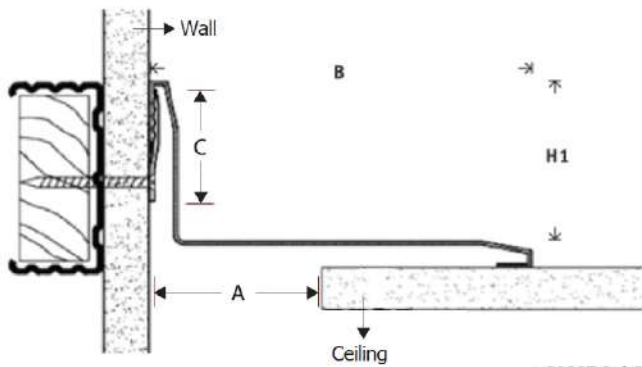

CWJ1/C
wall corner/ceiling corner support

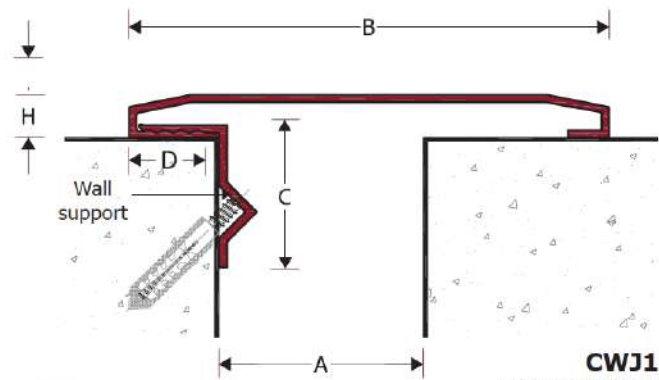

CWJ1
with wall/ceiling support

TYPE	A	B	C	D	H	H1	Total Movement
Flat Profile							
CWJ1 50	50	117	35	22	10.5	-	84
CWJ1 75	75	117	35	22	10.5	-	84
CWJ1 100	100	167	35	22	10.5	-	134
CWJ1 125	120	219	35	22	10.5	-	186
CWJ1 150	150	219	35	22	10.5	-	186
CWJ1 180	150	180	35	22	10.5	-	186
CWJ1 260	260	200	35	22	10.5	-	186
Corner Profile							
CWJ1/C 50	50	95	45	-	10.5	50	186
CWJ1/C75	75	95	45	-	10.5	50	95
CWJ1/C 100	100	160	45	-	10.5	50	95
CWJ1/C 125	120	205	45	-	10.5	50	160
CWJ1/C 150	150	205	45	-	10.5	50	205

Dimension in mm



Description

Anodised aluminum expansion joint with integrated weather seal for use in wall and ceilings. Installed beneath the plaster or wall board to provide a flush finish with no visible fixings.

Materials

Anodised aluminium 6063/T6.
Special PVC/EPDM joint seals, resistant to sunlight.

Supply Lengths

Aluminium Profile: 3m
PVC/EPDM Joint Seals: 50m
Custom lengths can be produced to order.

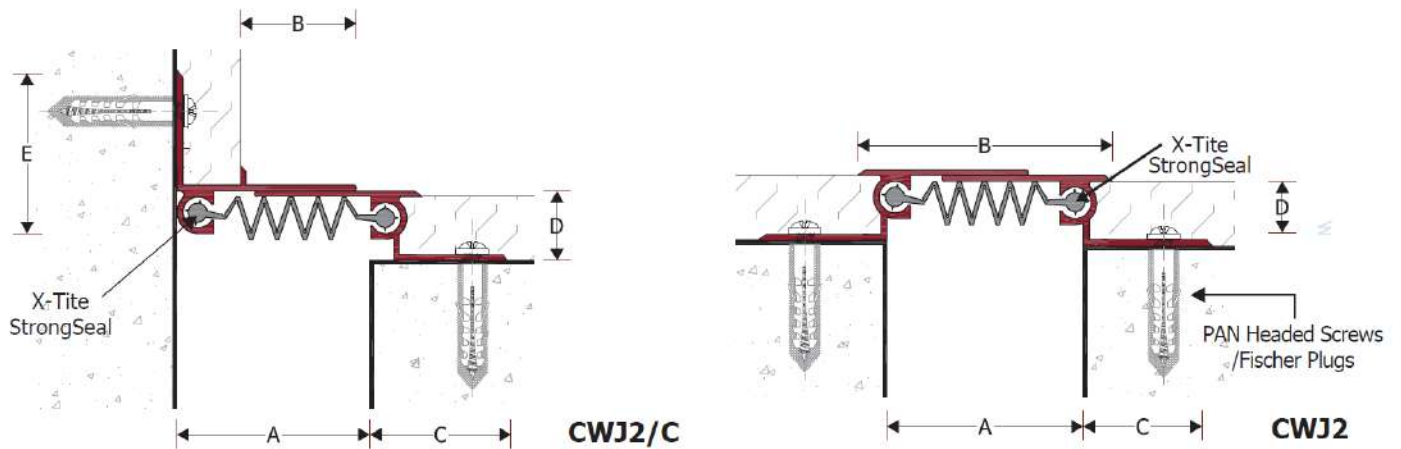

TYPE	A	B	C	D	E	*Total Movement
Flat Profile						
CWJ2 25	25	43	30	18	-	50
CWJ2 50	50	64	30	18	-	60
CWJ2 75	75	90	30	18	-	95
CWJ2 100	100	114	30	18	-	52
CWJ2 125	125	165	30	18	-	185
CWJ2 150	150	220	30	18	-	170
Corner Profile						
CWJ2/C 25	25	30	30	18	41	50
CWJ2/C 50	50	47	30	18	41	60
CWJ2/C 75	75	66	30	18	41	95
CWJ2/C 100	100	91	30	18	41	152
CWJ2/C 125	125	116	30	18	41	185
CWJ2/C 150	150	145	30	18	41	170

*Movements do not take into consideration PVC elongation at break (ISO R 527)

Dimension in mm



Description

Extruded aluminium seismic covers used to cover exterior and interior joints on finished walls & ceilings.

Materials

Material : Anodized aluminium 6063/T6

Insert: PVC/ EPDM seals

Supply Lengths

3m , custom lengths can be produced against minimum order.

PVC Joint Seal Colour



Black



Beige



Grey

(Other colors available subject to minimum order)

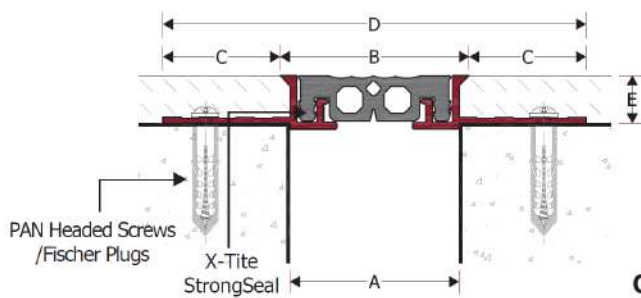

CWJ3

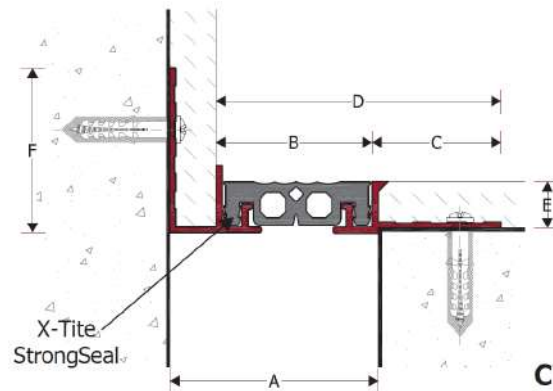

CWJ3/C

TYPE	A	B	C	D	E	*Total Movement
Flat Profile						
CWJ3 20	20	25	37	99	10	15
CWJ3 30	30	35	37	110	13	20
CWJ3 50	50	56	35	126	13	30
CWJ3 75	75	84	35	154	13	36
CWJ3 100	100	111	32	175	13	34
CWJ3 125	125	140	35	210	13	64
CWJ3 150	150	165	35	235	13	90
Corner Profile						
CWJ3/C 20	20	22	37	59	10	15
CWJ3/C 30	30	32	37	68	13	2
CWJ3/C 50	50	53	35	88	13	30
CWJ3/C 75	75	78	35	113	13	36
CWJ3/C 100	100	105	32	136	13	34
CWJ3/C 125	125	130	35	165	13	64
CWJ3/C 150	150	155	35	190	13	90

*Movements do not take into consideration PVC elongation at break (ISO R 527)

Dimension in mm

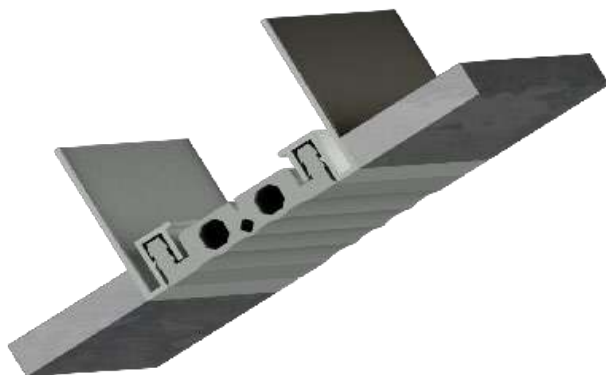

Description

Extruded aluminium expansion joints with PVC/ EPDM inserts on internal applications for ceilings with gypsum board /fall ceilings

Materials

Anodised aluminium 6063/T6
PVC/EPDM Joint Seals

Supply Lengths

Aluminium Profile: 4m
Joint Seals: 25m
Custom lengths can be produced to order.

PVC Joint Seal Colour



Black



Beige



Grey

(Other colors available subject to minimum order)

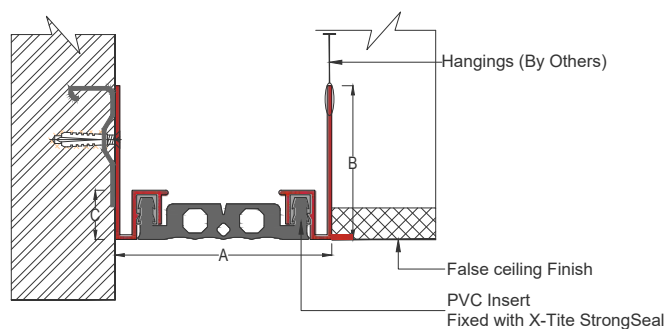
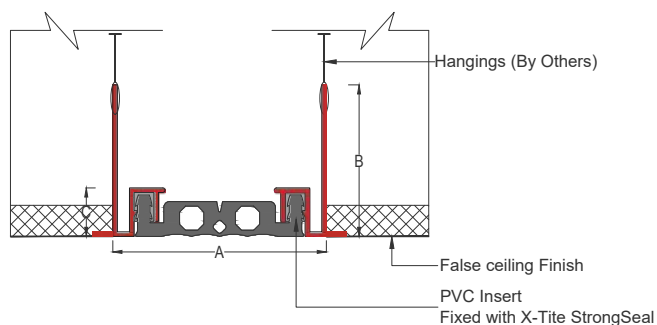

TYPE	A	B	C	D	E	*Total Movement
Flat Profile						
CWJ3 FC 20	20	25	37	99	10	15
CWJ3 FC 30	30	35	37	110	13	20
CWJ3 FC 50	50	56	35	126	13	30
CWJ3 FC 75	75	84	35	154	13	36
CWJ3 FC 100	100	111	32	175	13	34
CWJ3 FC 125	125	140	35	210	13	64
CWJ3 FC 150	150	165	35	235	13	90
Corner Profile						
CWJ3 FC/C 20	20	22	37	59	10	15
CWJ3 FC/C 30	30	32	37	68	13	2
CWJ3 FC/C 50	50	53	35	88	13	30
CWJ3 FC/C 75	75	78	35	113	13	36
CWJ3 FC/C 100	100	105	32	136	13	34
CWJ3 FC/C 125	125	130	35	165	13	64
CWJ3 FC/C 150	150	155	35	190	13	90

*Movements do not take into consideration PVC elongation at break (ISO R 527)

Dimension in mm



Description

High movement seismic expansion joint cover use in walls with finished such as tile, stone marbles, provides minimum effect of the appearance of the wall. Installed beneath the finish. It is also used to provide a continuation from floor of X-Joint CPS S floor profiles.

Materials:

Bases: Anodized aluminium 6063/T6

Supply Lengths

Bases: 4m

Custom lengths can be produced against minimum order.

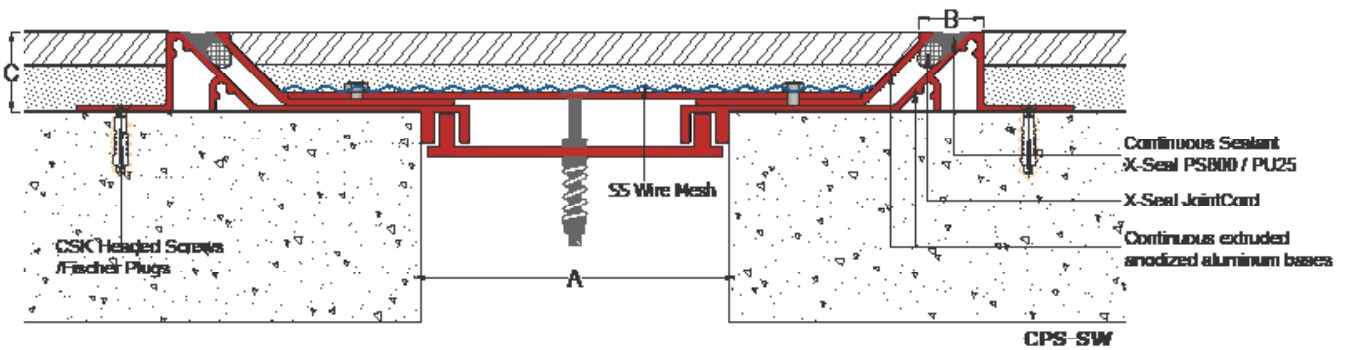

TYPE	A	B	C	Total Movement
CPS- SW 65	30	20	25	50
CPS- SW 75	75	20	25	50
CPS- SW 100	100	20	25	50
CPS- SW 125	125	20	25	50
CPS- SW 150	150	20	25	50

Dimension in mm



Description

Anodised aluminum PVC / EPDM /neoprene construction joint for use with tiles and stone. Installed when floor is being laid.

Materials:

Bases: Anodized aluminium 6063/T6
(Stainless steel or Brass available upon request).
Insert strip: PVC / EPDM / neoprene

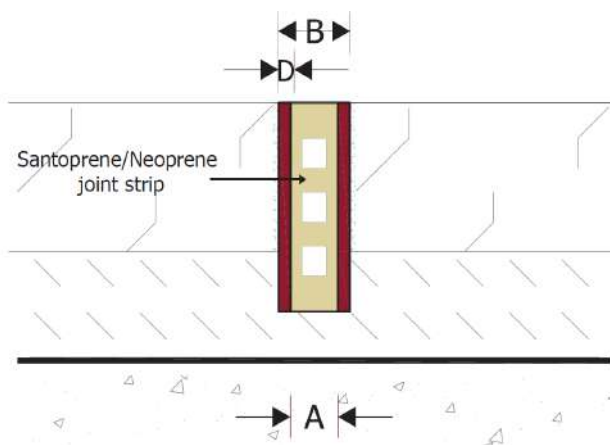

Joint Strip Colour



TYPE	A	B	C	D	Total Movement
CJ1 15/6	6	10	15	1.5/2	±2
CJ1 15/8	8	12	15	2	±2
CJ1 20/6	6	10	20	2	±2
CJ1 20/8	8	12	20	2	±2
CJ1 30/8	8	12	30	2	±2
CJ1 40/8	8	12	40	2	±2
CJ1 50/8	8	12	50	2	±2
CJ1 50/10	10	14	50	2	±2
CJ1 75/8	8	12	75	2	±2
CJ1 80/10	10	14	80	2	±2

Custom sizes can be produced upon request

Dimension in mm



Description

Anodized aluminum construction joint for use with tiles and stone. Installed beneath the screed.

Materials:

Bases: Anodized aluminium 6063/T6

Insert strip: PVC / EPDM / neoprene

Joint Strip Colour



Black



Beige



Grey (302,304)

(Other colors available subject to minimum order)

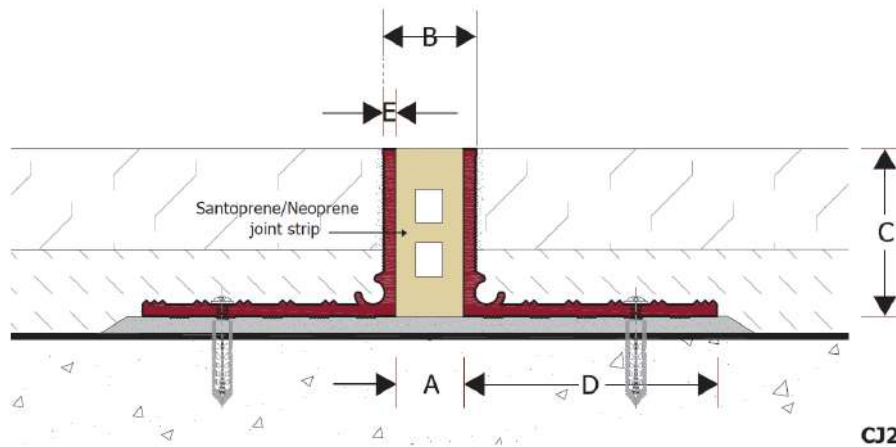

CJ2

TYPE	A	B	C	D (AL Series)	D (SS/BR Series)	E (AL Series)	Total Movement
CJ2 15/10	6.9	10	15	20	15	1.8	-4+2
CJ2 20/10	6.9	10	20	15	20	1.8	-4+2
CJ2 25/10	7.5	10	25	25	20	1.5	-4+2
CJ2 30/10	7.3	10	30	15	20	1.6	-4+2
CJ2 50/10	6.5	10	50	50	25	2	-4+2
CJ2 75/10	5.9	10	75	50	30	2.3	-4+2
CJ2 15/12	8.9	12	15	20	15	1.8	-4+2
CJ2 20/12	8.9	12	20	15	20	1.8	-4+2
CJ2 25/12	9.5	12	25	25	20	1.5	-4+2
CJ2 30/12	9.3	12	30	15	20	1.6	-4+2
CJ2 50/12	10.5	12	50	50	25	2	-4+2
CJ2 75/12	7.9	12	75	50	30	2.3	-4+2
CJ2 15/15	11.9	15	15	20	15	1.8	-4+2
CJ2 20/15	11.9	15	20	15	20	1.8	-4+2
CJ2 25/15	12.5	15	25	25	20	1.5	-4+2
CJ2 30/15	12.3	15	30	15	20	1.6	-4+2
CJ2 50/15	11.5	15	50	50	25	2	-4+2
CJ2 75/15	10.9	15	75	50	30	2.3	-4+2

Custom sizes can be produced upon request

Dimension in mm



Description

Anodized aluminum construction joint for use with tiles and stone. Installed beneath the screed.

Materials:

Bases: Anodized aluminium 6063/T6

Insert: EPDM / PVC

Joint Strip Colour



Black



Beige



Grey (302,344)

(Other colors available subject to minimum order)

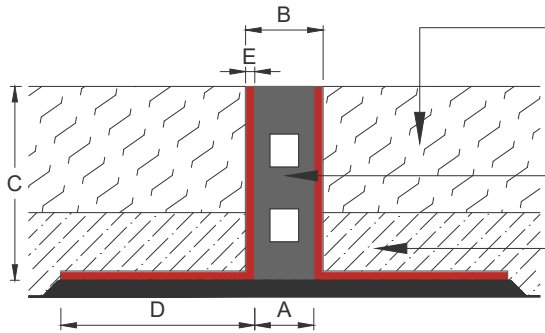

Tile/Stone/Marble Finish

PVC/EPDM Insert

Tile Adhesive

TYPE	A	B	C	D (AL Series)	D (SS/BR Series)	E (AL Series)	Total Movement
CJ2-SS 15/10	6.9	10	15	20	15	1.8	-4+2
CJ2-SS 20/10	6.9	10	20	15	20	1.8	-4+2
CJ2-SS 25/10	7.5	10	25	25	20	1.5	-4+2
CJ2-SS 30/10	7.3	10	30	15	20	1.6	-4+2
CJ2-SS 50/10	6.5	10	50	50	25	2	-4+2
CJ2-SS 75/10	5.9	10	75	50	30	2.3	-4+2
CJ2-SS 15/12	8.9	12	15	20	15	1.8	-4+2
CJ2-SS 20/12	8.9	12	20	15	20	1.8	-4+2
CJ2-SS 25/12	9.5	12	25	25	20	1.5	-4+2
CJ2-SS 30/12	9.3	12	30	15	20	1.6	-4+2
CJ2-SS 50/12	10.5	12	50	50	25	2	-4+2
CJ2-SS 75/12	7.9	12	75	50	30	2.3	-4+2
CJ2-SS 15/15	11.9	15	15	20	15	1.8	-4+2
CJ2-SS 20/15	11.9	15	20	15	20	1.8	-4+2
CJ2-SS 25/15	12.5	15	25	25	20	1.5	-4+2
CJ2-SS 30/15	12.3	15	30	15	20	1.6	-4+2
CJ2-SS 50/15	11.5	15	50	50	25	2	-4+2
CJ2-SS 75/15	10.9	15	75	50	30	2.3	-4+2

Custom sizes can be produced upon request

Dimension in mm



Description

Anodized aluminum construction joint for use with tiles and stone. Installed when floor finish is being laid.

Materials

Stainless steel strip 304 or 316 (Anodized aluminium 6063/T6 and brass available upon request).
 X-Seal JointBoard P60 (Refer to product datasheet)
 Nelson Stud Grade 304 Size: M6x30mm

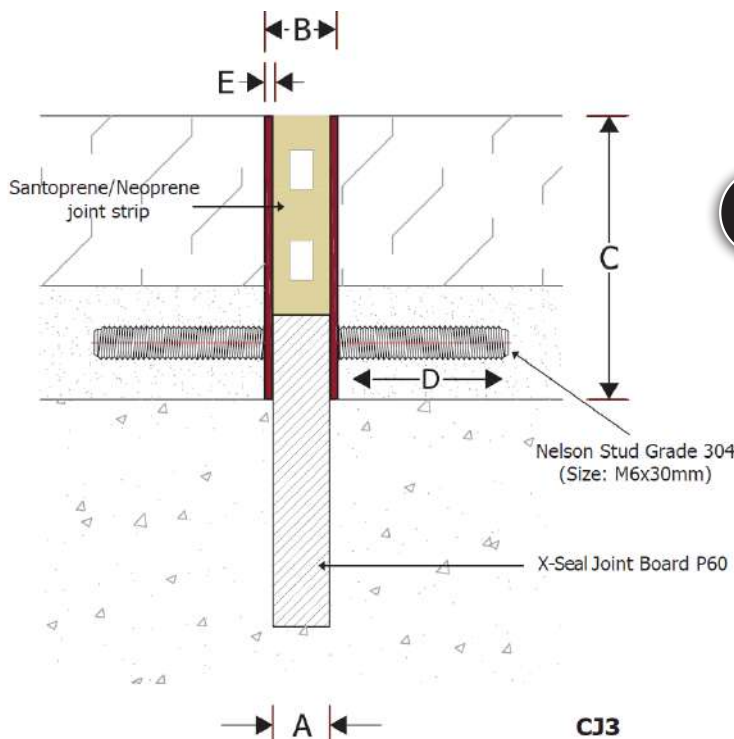

Joint Strip Colour



TYPE	A	B	C	D	E	Total Movement
CJ3 40/10	10	13	40	30	1.5	±2
CJ3 50/10	10	13	50	30	1.5	±2
CJ3 60/10	10	13	60	30	1.5	±2
CJ3 80/10	10	13	80	40	1.5	±2
CJ3 100/10	10	13	100	40	1.5	±2

Custom sizes can be produced upon request

Dimension in mm



Description

Anodized aluminum polyurethane construction joint for use with tiles and stone. Accepts higher movement than neoprene. Installed when floor finish is being laid.

Materials

Anodized aluminium 6063/T6.
(Stainless steel and brass available upon request).
One component polyurethane sealant
PVC or EPDM (sub-layer)

Supply Lengths

3m, custom size can be produced upon request.

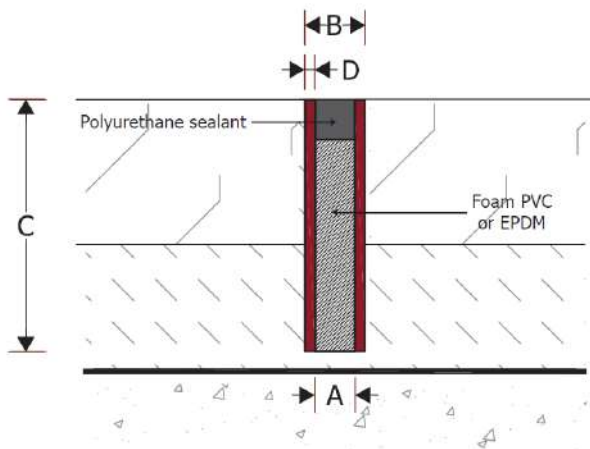

TYPE	A	B	C	D	Total Movement
CJ4 20/6	6	10	20	2	±2
CJ4 30/6	6	10	30	2	±2
CJ4 40/6	6	10	40	2	±2
CJ4 50/6	6	10	50	2	±2
CJ4 75/6	6	10	75	2	±2
CJ4 80/6	6	10	80	2	±2

Custom sizes can be produced upon request

Dimension in mm



Description

Extruded anodized aluminium joint separators for screed and floor finishes.

Materials

Anodized aluminium 6063/T6

Supply Lengths

3m or 6m, can be cut to exact installation length prior to delivery.

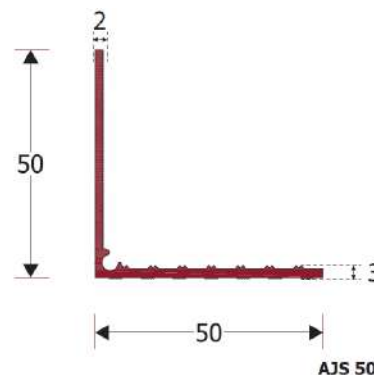
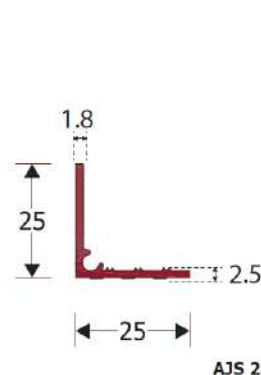



Description

Fully waterproof joint system for roof joints 10mm to 100mm wide used to cover and seal joints in accessible roofs.

Materials

Cover plate: Anodized aluminium grade 6063/T6
 (Stainless steel 304 or 316 are also available upon request).
 Joint seals: PVC / EPDM
 Waterproofing: X-Pruf Plyliner PVC system

Supply Lengths

Aluminium: 4m
 Joint seals: 20m roll
 Custom lengths can be produced to order.

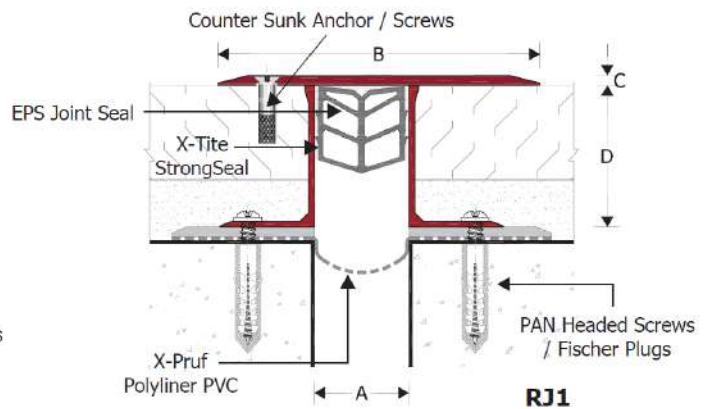
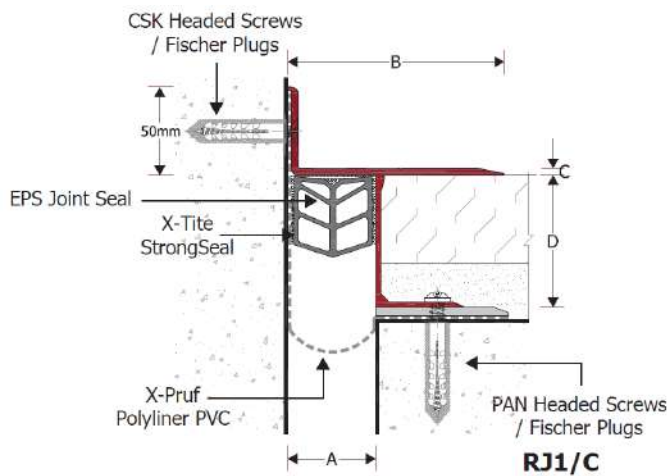

TYPE	A	B	C	D	*Total Movement
Flat Profile					
RJ1 10/15	10-15	117	5	33/45/75	20
RJ1 15/20	15-20	117	5	33/45/75	30
RJ1 20/30	20-30	117	5	33/45/75	40
RJ1 30/40	30-40	117	5	33/45/75	50
RJ1 40/50	40-50	170	5	33/45/75	65
RJ1 50/80	50-80	170	5	33/45/75	100
RJ1 80/100	80-100	170	5	33/45/75	120
Corner Profile					
RJ1/C 10/15	10-15	67	4	33/45/75	20
RJ1/C 15/20	15-20	67	4	33/45/75	30
RJ1/C 20/30	20-30	67	4	33/45/75	40
RJ1/C 30/40	30-40	67	4	33/45/75	50
RJ1/C 40/50	40-50	67	4	33/45/75	65
RJ1/C 50/80	50-80	120	4	33/45/75	100
RJ1/C 80/100	80-100	120	4	33/45/75	120

*Movements depend on the cover plate width

Dimension in mm



Description

High movement expansion joint system use on open deck floors subject to slow/medium traffic. Installed beneath the screed and protected with suitable cover.

Materials

Cover plate: Anodized aluminium 6063/T6
 Joint support: White aluminium (Powder coated RAL 9006)
 Joint Seals: PVC / EPDM

Supply Lengths

Aluminium Profile: 4m
 Joint Seal: 25m roll
 Custom lengths can be produced to order

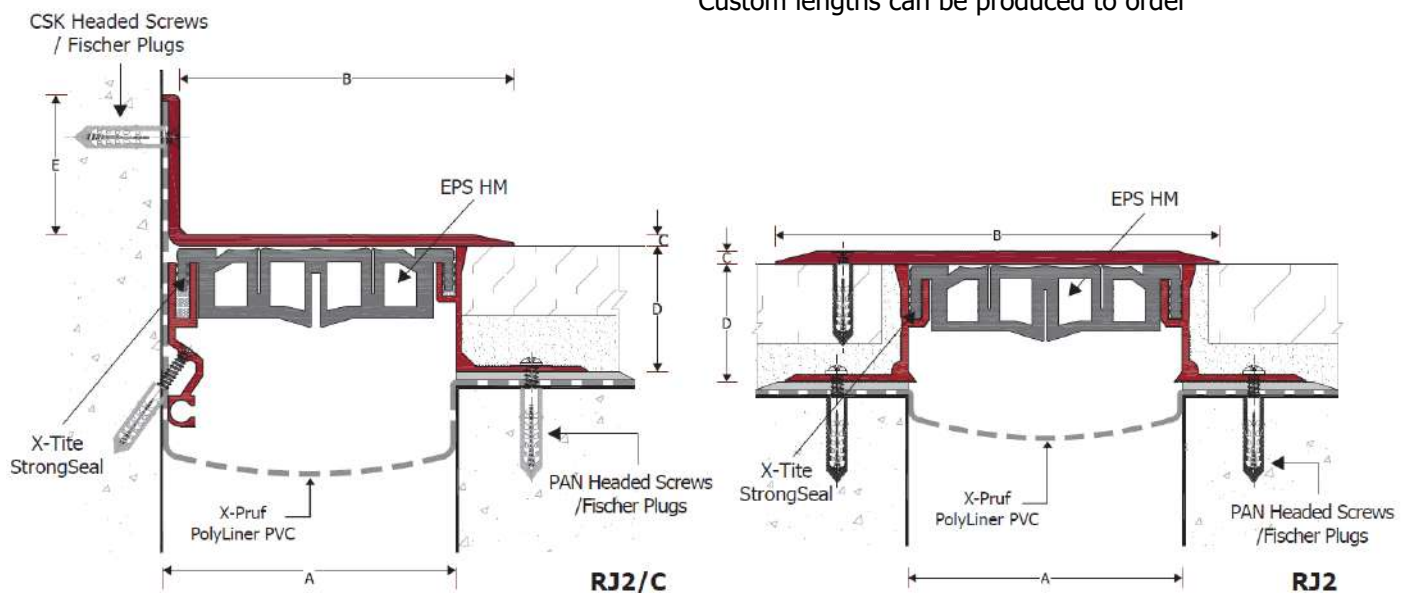

*Movements depend on the cover plate width

TYPE	A	B	C	D	E	*Total Movement
Flat Profile						
RJ2 50	50	117	4	45	-	70
RJ2 100	100	170	4	45	-	125
RJ2 150	150	219	4	45	-	180
RJ2 200	200	250	4	45	-	230
Corner Profile						
RJ2/C 10/15	50	70	4	45	50	60
RJ2/C 15/20	100	120	4	45	50	120
RJ2/C 20/30	150	169	4	45	50	200
RJ2/C 30/40	200	170	4	45	50	320

Dimension in mm

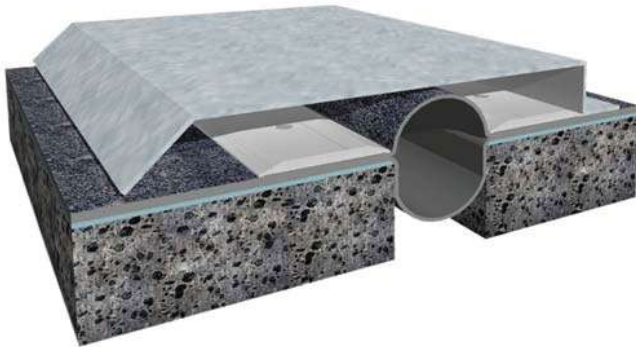

Description

High movement (seismic) anodised aluminium/ PVC wall joint for use with a wall finish up to 16mm thick. Joint must fixed on to a concrete or masonry substrate.

Materials

Joint plate: 2mm thick preformed galvanized sheet
 Fixing strip: Mill finish aluminium
 Waterproofing membrane: X-Pruf Polyliner PVC

Supply Lengths

Joint plate: 2.44m
 Fixing strip: 3m
 Membrane: 25m
 Custom lengths can be produced to order.

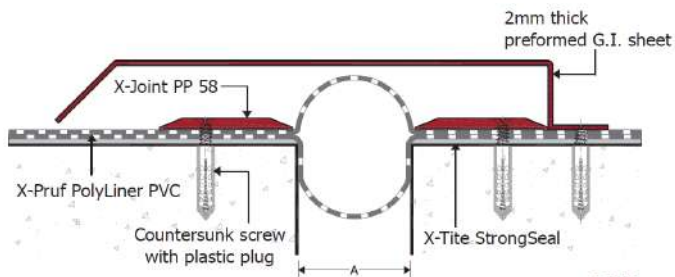

RJ3-FL

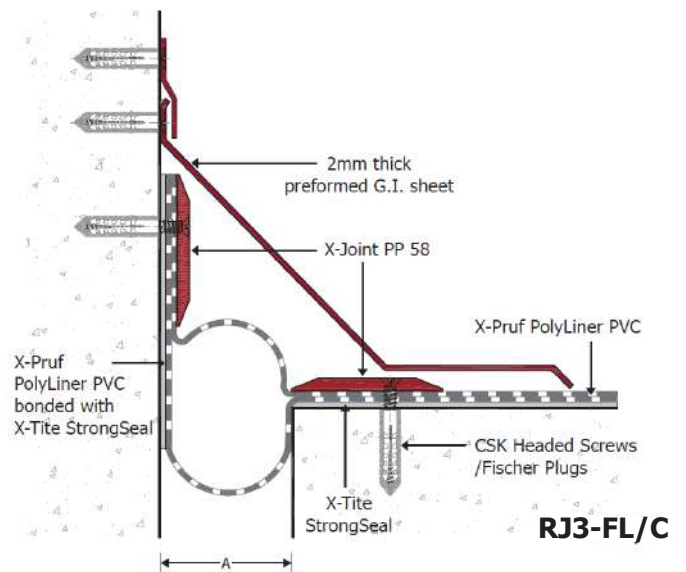
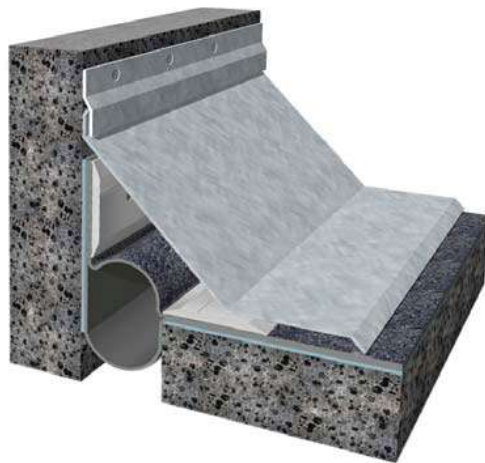

RJ3-FL/C

TYPE	A	*Total Movement
Flat Profile		
RJ3-FL 50	50	50
RJ3-FL 100	100	100
RJ3-FL 150	150	150
RJ3-FL 200	200	200
Corner Profile		
RJ3-FL/C 50	50	50
RJ3-FL/C 100	100	100
RJ3-FL/C 150	150	150
RJ3-FL/C 200	200	200

Dimension in mm

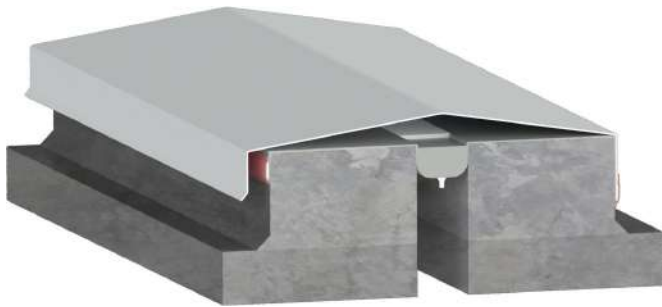

Description

High movement (seismic) anodised aluminium/ PVC wall joint for use with a wall finish up to 16mm thick. Joint must be fixed on to a concrete or masonry substrate.

Materials

Joint Cover: 2mm thick preformed aluminum cover plate
 Fixing Strip: Anodised aluminum T6/6063
 Waterproofing membrane: X-Pruf PolyLiner PVC
 Waterproofing Sealant: X-Tite Strong Seal

Supply Lengths

Joint Plate: 2.44m
 Fixing Strip: 3m / pcs
 Membrane: 20m roll

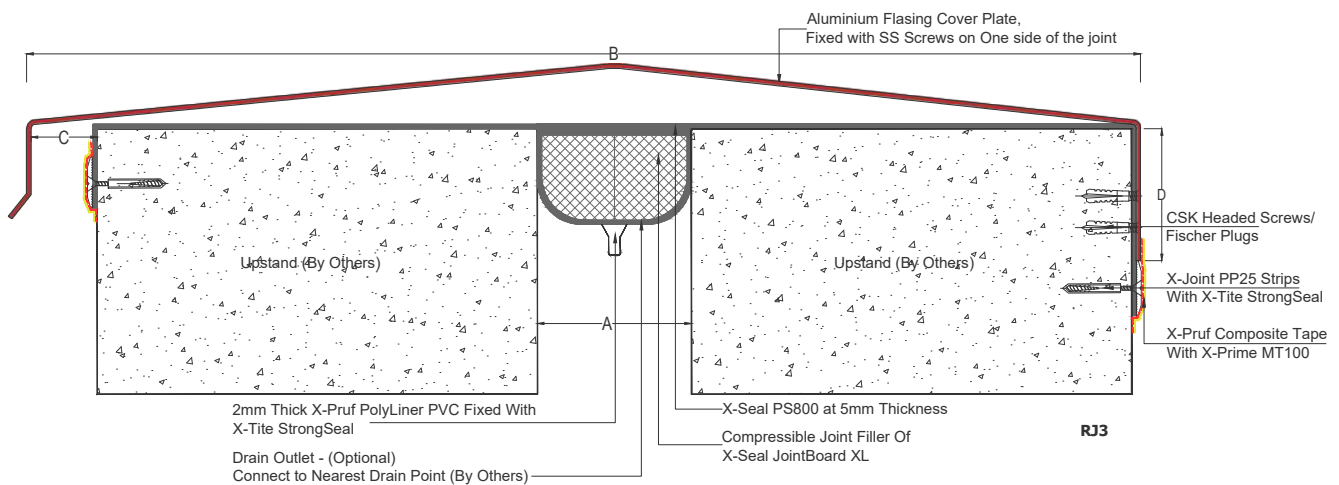

TYPE	A	*Total Movement
Flat Profile		
RJ3-AL 50	50	70
RJ3-AL 100	100	70
RJ3-AL 150	150	70
RJ3-AL 200	200	70
Corner Profile		
RJ3-AL 50	50	70
RJ3-AL 100	100	70
RJ3-AL 150	150	70
RJ3-AL 200	200	70

Dimension in mm



Description

High Movement seismic aluminium cover system to use on roof upstand provides fully waterproofed termination between roof slab waterproofing.

Materials

Base: Anodised aluminium T6/6063
 Cover Plate: Stainless steel, powder coated aluminum GI sheet

Waterproofing System: X-Pruf Polyliner PVC system

Supply Lengths

Base: 4m
 Fixing strip: 3m
 Membrane: 25m
 Custom lengths can be produced to order.

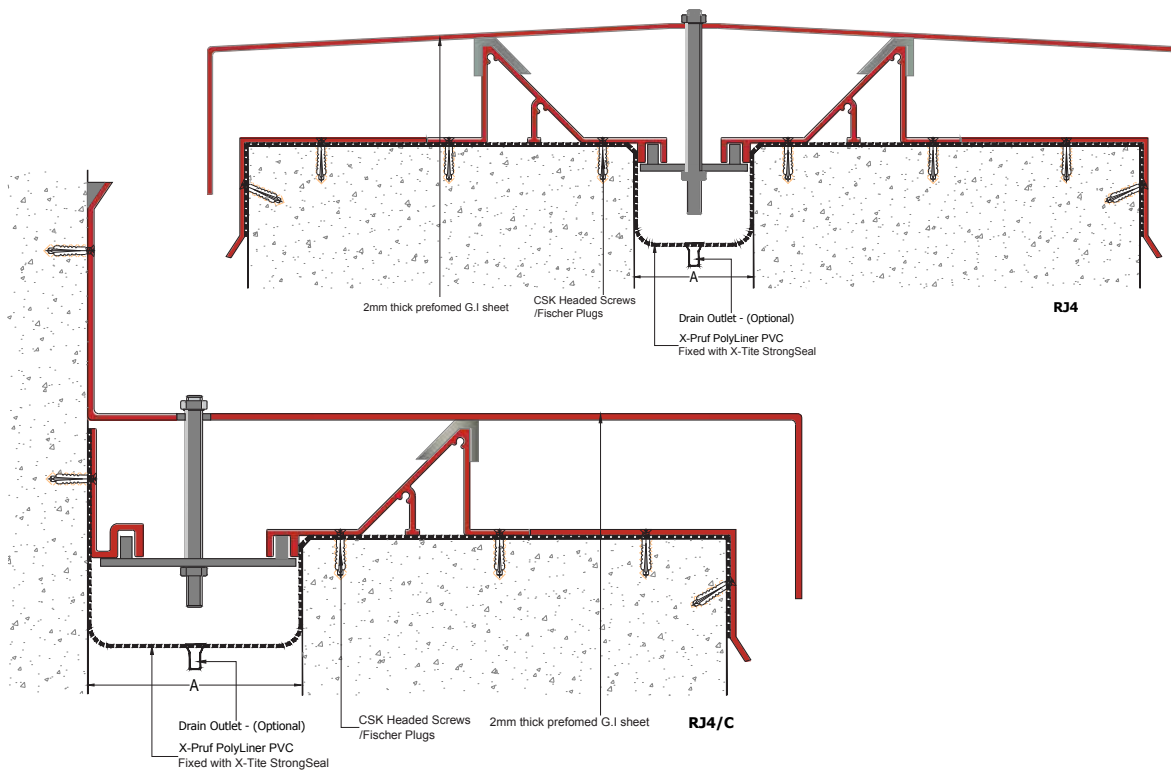

TYPE	A	*Total Movement
Flat Profile		
RJ4 50	50	50
RJ4 100	100	100
RJ4 150	150	150
RJ4 200	200	200
Corner Profile		
RJ4 50	50	50
RJ4 100	100	100
RJ4 150	150	150
RJ4 200	200	200



Description

Range of extruded aluminum joint covers that are suitable for use in a wide range of internal and external applications in commercial, institutional and industrial buildings. While aesthetically pleasing they are particularly useful for protection of elastomeric joint sealants and fire barriers.

Materials

Anodized aluminium 6063/T6 or mill finish aluminum. Polished finish and powder coated profiles can be provided in a wide range of colors.

Supply Lengths

3m or 6m lengths
Custom lengths can be produced to order.

Floor Profiles

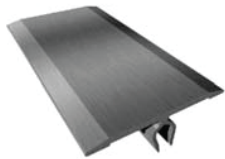

F55F, F70F & F100F

Wall Profiles



W70C

Corner Profiles

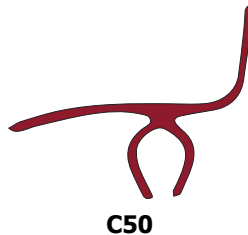

C50

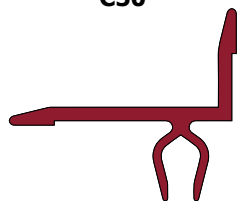
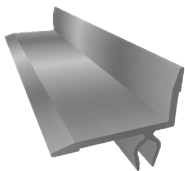

C100

Spring Clips

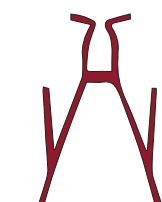

SS40 and SS60

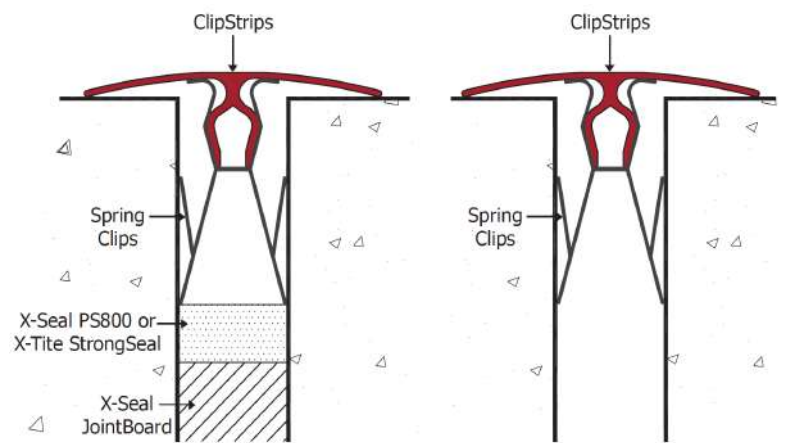

Profile Type	Profile Width	Joint Width
Floor Profile		
F55F	55	20 to 35
F70F	70	30 to 45
F100F	100	40 to 60
F117F	117	60 to 70
Wall Profile		
W55G	55	25 to 35
W70C	70	15 to 50
Corner Profile		
C50	53	15 to 50
C100	75	50 to 60
Spring Clips		
SS40	40	20 to 30
SS60	60	30 to 50

Dimension in mm

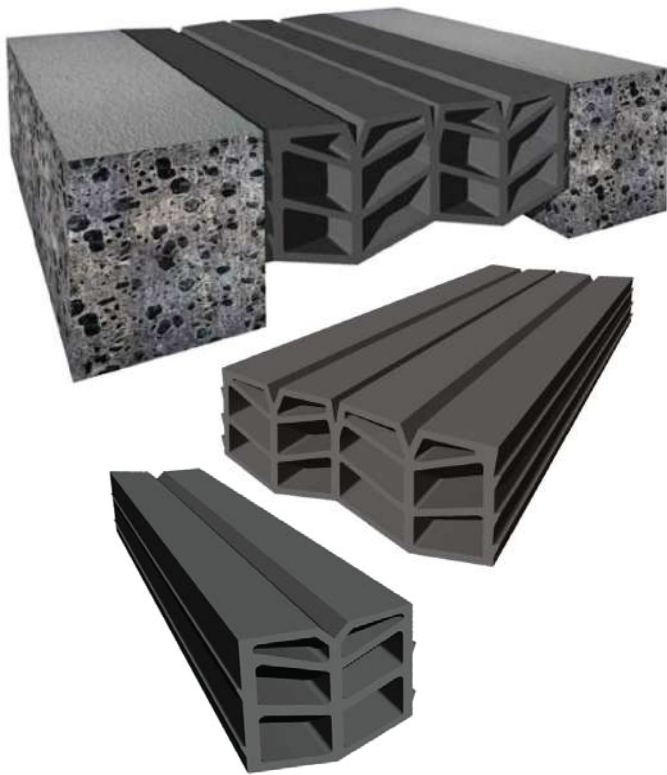

Description

Seismic waterproofing expansion joint seals for use in mechanical expansion joints.

Materials

EPDM

Joint Seal Colour



Black

Beige

Grey

(Other colors available subject to minimum order)

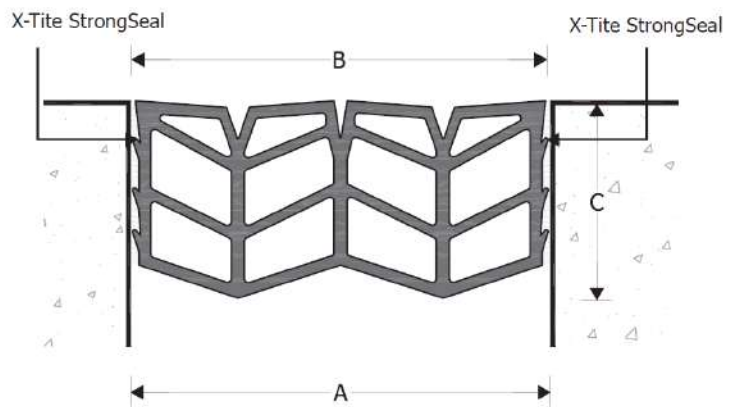
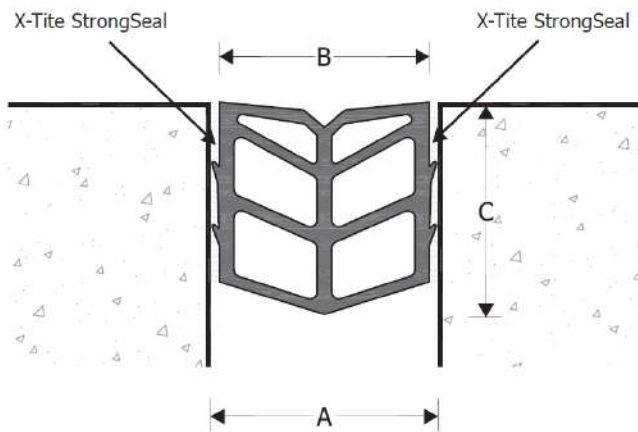

TYPE	A	B	C	Total Movement
EPS 20/20	15-20	20	20	20
EPS 30/30	15-20	30	30	30
EPS 40/30	20-30	40	35	40
EPS 50/40	30-40	50	40	50
EPS 65/40	40-50	65	50	65
EPS 100/48	50-80	100	48	100
EPS 125/60	80-100	125	60	120

Dimension in mm

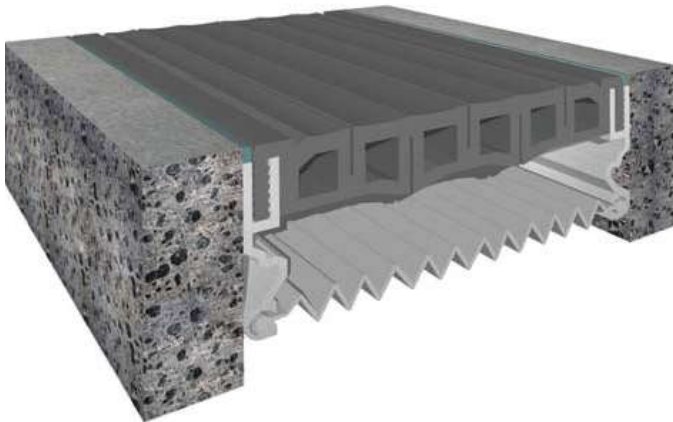

Description

High movement (seismic) waterproofing expansion joints for use in vertical and horizontal applications such as walls and slabs.

Materials

Profile: Anodized aluminium 6063/T6 natural finish
 Joint Seals: UV resistant PVC.

Supply Lengths

Aluminium Profile: 3 or 4m
 Joint Seals: 25m roll
 Custom lengths can be produced to order.

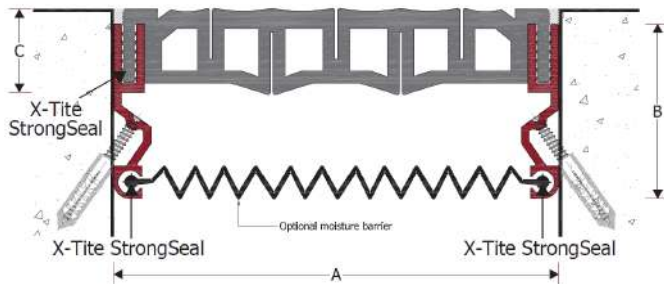

Colour





Black Beige Grey

(Other colors available subject to minimum order)



EPS-HM 50



EPS-HM 100

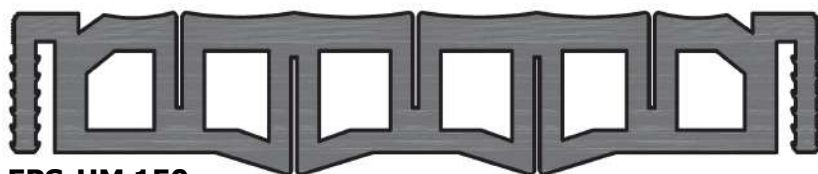

EPS-HM 150



EPS-HM 200

TYPE	A	B	C	Total Movement
EPS HM50	50	58	25	50
EPS HM100	100	58	25	100
EPS HM150	150	58	25	150
EPS HM200	200	58	25	200

Dimension in mm

Description

Pre-formed heavy duty joint seal for use in mechanical expansion joints.

Materials

Profile: Anodized aluminium 6063/T6 natural finish
Joint insert: EPDM

Supply Lengths

Aluminium Profile: 2.44 or 3m
Joint Seals: 25m
Custom lengths can be produced to order.

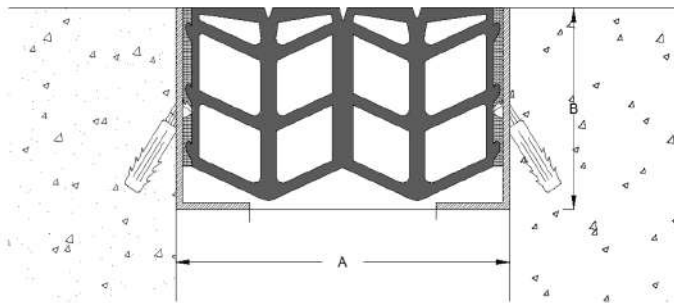

Colour



Black



Grey

(Other colors available subject to minimum order)

TYPE	A	B	C	± Total Movement
EPS-HD 25	10-15	30	20	15
EPS-HD 50	30-50	55	40	25
EPS-HD 75	55-75	82	45	35
EPS-HD 100	80-100	110	50	50
EPS-HD 125	105-150	137	55	60
EPS-HD 150	130-200	165	60	75
EPS-HD 200	155-200	225	60	100

Dimension in mm

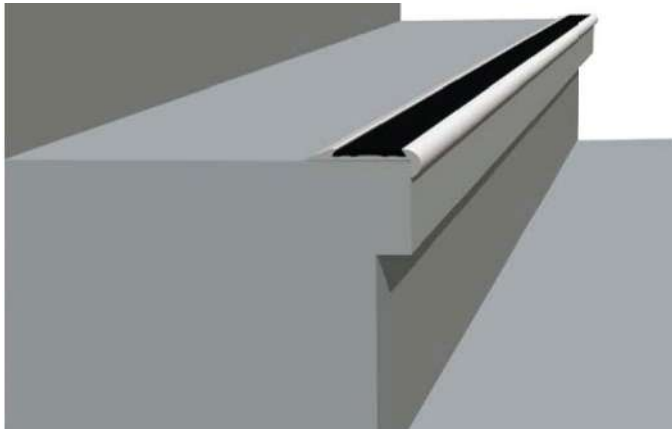

Description

Anodized aluminium stair nosings.

Materials

Anodized aluminium 6063/T6

Insert SN45 RS EPDM only

Insert SN45 Carbo™ only: Carbo™ anti-slip grains embedded in epoxy resin.

Supply Lengths

3m or 6m lengths. Can be cut to exact installation length prior to delivery.

SN 45 AA1

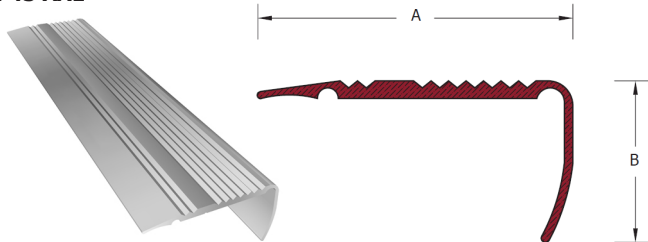

SN 45 Carbo™ 1

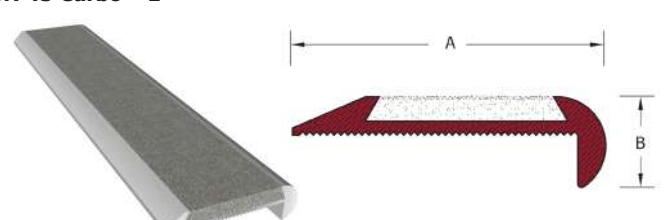

SN 45 AA2

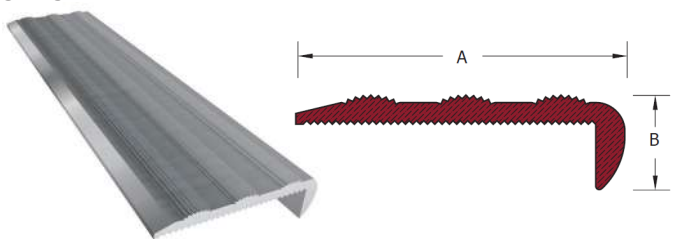

SN 45 Carbo™ 2

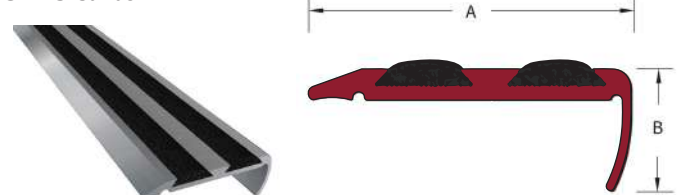

SN 45 RS

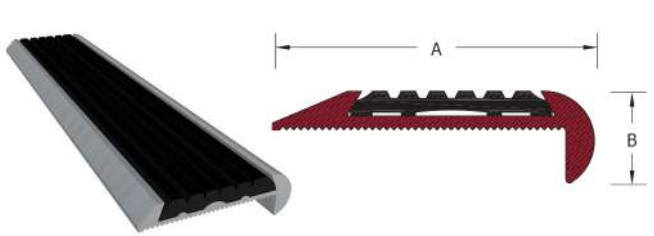

SN 50 Carbo™ 3



SN 50

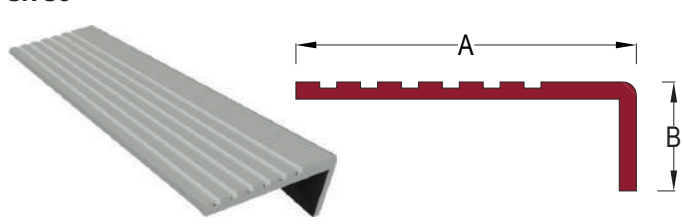

SN 51 Carbo™ 4



SN 80

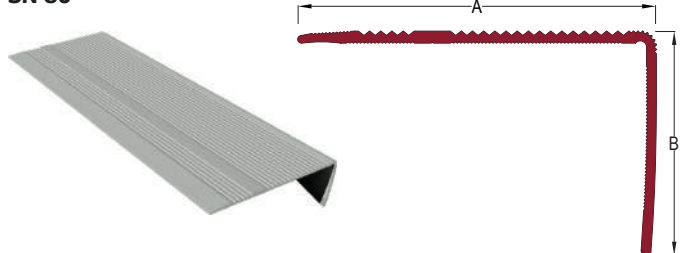

TYPE	A	B
SN 45 AA/1	45	23
SN 45 AA/2	46	13
SN 45 RS	47	13
SN 50	50	16
SN 80	80	40
SN 80 RS3	48	13
SN 45 Carbo™ 1	48	13
SN 45 Carbo™ 2	49	13
SN 50 Carbo™ 3	50	50
SN 51 Carbo™ 4	51	26
SN 80 Carbo™ 3	80	40

Dimension in mm

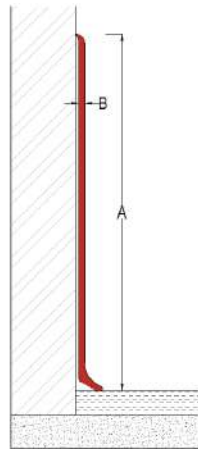

Description

Anodized aluminium floor skirting. Installed after the completion of floor finish.

Materials

Anodized aluminium grade 6063/T6. Can be in mill finish/powder coated.

Supply Lengths

Standard length is 3m.
Custom lengths can be produced against our minimum order level.

TYPE	A	B
Skirting 100	100	1.7
Skirting 100	150	2.5

Dimension in mm

AluCove

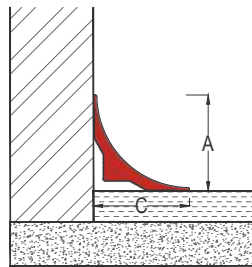
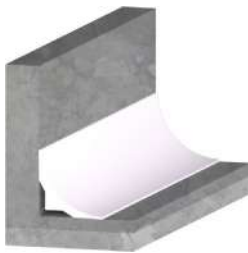

AluCove 30

Description

Anodized aluminium floor skirting. Installed after the completion of floor finish.

Materials

Anodized aluminium grade 6063/T6. Can be in mill finish/powder coated.

Supply Lengths

Standard length is 3m.
Custom lengths can be produced against our minimum order level.

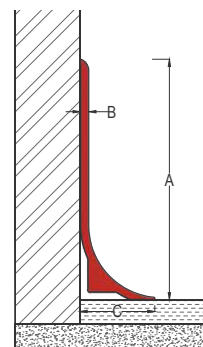

AluCove 100

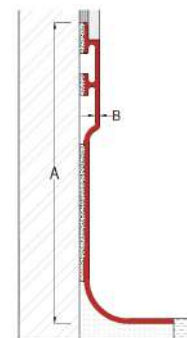

AluCove W130

TYPE	A	B	C
AluCove 30	30	3	31
AluCove 100	100	3.5	31
AluCove W130	100	1.7	40

Selected Projects



DCHD Creek Horizon
Dubai UAE

Jewel of the Creek
Dubai UAE



Sobha Hartland
Dubai UAE



Deira City Center
Dubai UAE



Maryam Island
Sharjah UAE



City of Lights Al Reem Island Development
Abu Dhabi UAE



Selected Projects



SAVICO
Ho Chi Minh
Vietnam

**Singapore Expo Convention
& Exhibition Centre**
Singapore



**New Doha
International Airport**
Doha Qatar



Oman National Museum
Majilis Oman



**Oasis Hospital
Development Al Ain**
Abu Dhabi UAE



**Eastern Mangrove
Hotel Apartments**
Abu Dhabi UAE



Selected Projects



**Yas Island,
Marina Hotel & F1 Circuit
Abu Dhabi UAE**



**Hamdan Bin Mohammed Bin
Rashid Sports Complex
Dubai UAE**



**Emirates Financial Towers
Dubai UAE**



**Iranian Hospital
Dubai UAE**



**American School
Dubai UAE**

**Sky Courts
Dubai UAE**



Selected Projects



Silicon Oasis
Dubai UAE

Al Jubail Market
Government of Sharjah
Sharjah UAE



Al Ain Stadium & Mixed Use
Development
Al Ain UAE



Al Waha Tower
Sharjah UAE



Al Fahidi Market
Dubai UAE



X-Calibur® supplies products that comply with the properties shown on the current data sheets. In the unlikely event that products supplied are proved to not comply with these properties, then we will replace the non-compliant product or refund the purchase price.

X-Calibur® does not warrant or guarantee installation of the products as it does not have control over the installation or end use of the products.

Any suspected defects must be reported to X-Calibur® in writing within five working days of being detected.

X-Calibur International FZC makes no warranty as to merchantability or fitness for a particular purpose and this warranty is in lieu of all other warranties express or implied.

X-Calibur International FZC shall not be liable for damages of any sort including the report or consequential damages, downtime or delay.

©2021 X-Calibur International FZC. All Rights Reserved.



X-Calibur Expansion Joints Manufacturing LLC
Al Huraiz Building, Umm Ramool, Rashidiya - Dubai
P.O. Box 25973 | T ++971 4330 4409 | www.x-calibur.us

Connect with us!
[xcaliburglobal](https://www.instagram.com/xcaliburglobal)

